

# NEWMAN

SANITARY GASKET COMPANY



## "O"-RING SIZING GUIDE



# How to size your "O"-Rings

If you don't know the size or number of the "O"-Ring, you will need to determine the I.D. and width (see illustration below); or you may enclose a sample of the size you need with your quote request or order.

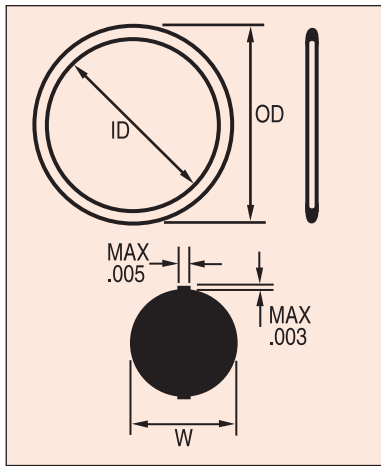

If your FDA rubber requirements are demanding, you can be assured that Newman will meet your exact standards precisely. For specific applications, data and design assistance, give us a call.

# Newman Elastomer Characteristics

Newman Sanitary Gasket Company has the largest stock of FDA compliant "O"-Rings in North America ready to serve your requirements whether your needs are small or large. You will find our quality "O"-Rings have the mechanical properties you are seeking, plus the most demanding quality criteria.

**Buna-N compound No. 1107** material will handle most food, dairy, pharmaceutical and sanitary services. It is the backbone of the food and edibles industries, has excellent resistance to compression set, tear and abrasion. It has good acid and mild alkali resistance and is good for vegetable oil service. Rated at -40° to 225°F.

**EPDM (ethylene propylene rubber) compound No. 2107** is excellent for hot water and steam service up to 325°F. It is very abrasion-resistant and has excellent resistance to ozone, sunlight or weather and de-ionized water. EPDM also has good tensile strength and good resistance to mild acids, alkalis and alcohols. Rated -65°F to 350°F (short term to 400°F).

**CMPD No. 2197** material will handle soft drink applications and is very well suited for products containing aspartame, Nutra-Sweet®.

**Viton® (bisphenol cured fluorocarbon elastomer) compound No. 3207** material has excellent mechanical, chemical, heat and steam resistance. It is particularly well-suited for hot fatty and oil products. Viton® is especially good for hard vacuum service because of its high molecular weight and low gas permeability. It has been used to -65°F in some static seals — flexibility, 0°F to 400°F under continuous duty and will take 600°F for short periods of time. Rated at -20°F to 400°F (short terms to 600°F).

**Silicone Platinum cured compound No. 4137 (red) and No. 4749 (clear)** material is known for its standard of purity and non-leaching characteristics. Its ability to withstand many chemicals and combination of chemicals is the reason it is so popular with the pharmaceutical industry. Silicone has excellent low temperature flexibility — to 100°F in dry heat; 450°F is the top for continuous duty with 600°F possible for short periods. Rated at -80° to 400°F.

**Kalrez® perfluoroelastomer compounds No. 6230 (black) and 6221 (white)** last longer and seal more effectively than other elastomers due to their exceptional chemical resistance and thermal stability. Kalrez® o-rings can withstand attack by more than 1,800 chemicals, including many acids and amines that cause other elastomers to fail due to excessive swelling. Even after long-term exposure to temperatures up to 600°F, Kalrez® retains its elasticity and recovery properties better than other high temperature elastomers

Newman "O"-Ring sizes are the same as those established in AS568A, which includes more available sizes than several of the military specifications. These sizes and tolerances were published by SAE and have been approved by the Air Standards Committee (membership by U.S.A., Australia, Canada, New Zealand, and the United Kingdom) July 1974 and are illustrated in the table below and on the following pages.

## AS568A Standard Dimensional Tolerance Table (RMA A2) Molded Solid Rubber Products

Size (inches)	Fixed	Closure
Above Incl.		
0 - .40	±.006	±.008
.40 - .63	.008	.010
.63 - 1.00	.010	.013
1.00 - 1.60	.013	.016
1.60 - 2.50	.016	.020
2.50 - 4.00	.020	.025
4.00 - 6.30	.025	.032
6.30 & over:		
To find fixed dimensional tolerances, multiply by 0.4%.		

# Groove Finish

Straight-sided grooves are best to prevent extrusion or nibbling, but 5° sloping sides are easier to machine and are suitable for pressures up to 1500 psi. Finish sides to 32 RMS with no burrs, nicks, or scratches. Locate in a shaft or rod, if possible, for easier machining and installation.

The rubbing surfaces should be 8 to 16 RMS without longitudinal or circumferential scratches. Best surfaces are honed, burnished, or hard chromeplate. Soft or stringy metals such as aluminum, brass, bronze, monel, or free machining stainless steel should not be used for moving seals. A 63RMS finish may be used for static glands.

Finishes below 5 RMS wipe too clean for good moving seal life. Steel or cast iron cylinder bores are preferred. They should be thick enough not to expand or breathe with pressure, otherwise the radial clearance gap may expand and contract with pressure fluctuations causing nibbling of the ring. Pistons should be softer than cylinder materials to avoid scratching.

## (E) Maximum Radial Clearance Gap to Prevent Extrusion

Maximum Pressure PSI	"O"-Ring Hardness (Shore A)				
	50	60	70	80	90
100	.008"	.009"	.010"	.013"	.016"
250	.005"	.008"	.009"	.012"	.014"
500	.003"	.005"	.008"	.010"	.012"
1,000	.001"	.003"	.005"	.008"	.010"
1,500	.000"	.001"	.003"	.005"	.008"
2,000		.000"	.002"	.004"	.005"
3,000			.000"	.002"	.003"
4,000				.000"	.001"
5,000					.000"

Clearances apply to dynamic "O"-Rings with no backup washers for .139 in. (3.53mm) "O"-Ring cross-sections and up. Smaller cross-sections do not give effective moving seal life, are less resistant to extrusion, and may be critical in sealing high frequency dynamic motion.

## Static Tolerances

SIZE No.	A + -000	B +000 -	C +000 -	D + -000
001-012	+001	-001	-001	+001
013-050	+002	-002	-002	+002
102-178	+003	-003	-003	+003
201-284	+004	-004	-003	+003
309-395	+005	-005	-003	+003
425-475	+006	-006	-003	+003

## Dynamic Tolerances

SIZE No.	A + -000	B +000 -	C +000 -	D + -000
001-012	+001	-001	-001	+001
012-116	+003	-003	-003	+003
201-222	+004	-004	-004	+004
309-349	+005	-005	-005	+005
425-460	+006	-006	-006	+006

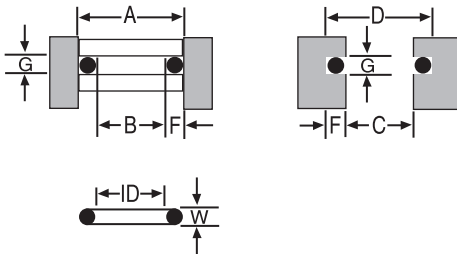

## (G) Groove Dimensions

+005  
-000

## Commercial Applications

"O"-Ring Cross-Section	ROLLING SEALS			NON-ROLLING SEALS *		
	No Backup Washer	One Backup Washer	Two Backup Washer	No Backup Washer	One Backup Washer	Two Backup Washer
.070	.093	.149	.207	.083	.138	.205
.103	.140	.183	.245	.120	.171	.238
.139	.185	.225	.304	.160	.208	.275
.210	.285	.334	.474	.235	.311	.410
.275	.375	.440	.579	.310	.408	.538

\* These groove widths are for compounds that free swell less than 15%. Suitable extra allowances should be made for higher swell.

	BUNA-N (1107)	EPDM (2107)	VITON® (3207)	SILICONE (4137)	SILICONE (4749)
Specific Gravity	1.38	1.20	1.94	1.20	1.22
Tensile Strength, psi	2010	1705	1910	1256	1130
Elongation, %	405	450	310	307	610
300% Modulus, psi	1430	1260	1610	1245	450
Hardness, Shore A, pts.	70	71	74	75	80
Compression Set, % (Method B, 22 hrs. @ 100°C)	21.6	27.5	26.7	24.5	6.5

These materials meet the criteria of the FDA, Title 21, Paragraph 177.2600, as a direct contact material with food and pharmaceutical products.

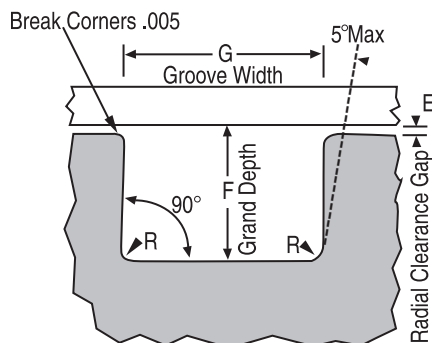

Your Part Number	Newman Size Number	Nominal Size	INCH STANDARD				METRIC STANDARD			
			Inside Diameter		Cross Section W		Inside Diameter		Cross Section W	
			In.	±	In.	±	MM.	±	MM.	±
	001	1/32 x 3/32 x 1/32	.029	.004	.040	.003	0.74	0.10	1.02	0.08
	902 1/2	1/16 x 1/8 x 1/32	.070	.004	.040	.003	1.78	0.10	1.02	0.08
	002	3/64 x 9/64 x 1/32	.042	.004	.050	.003	1.07	0.10	1.27	0.08
	003	1/16 x 3/16 x 1/16	.056	.004	.060	.003	1.42	0.10	1.52	0.08
	004	5/64 x 13/64 x 1/16	.070	.005	.070	.003	1.78	0.13	1.78	0.08
	005	3/32 x 7/32 x 1/16	.101	.005			2.57	0.13		
	006	1/8 x 1/4 x 1/16	.114	.005			2.90	0.13		
	007	5/32 x 9/32 x 1/16	.145	.005			3.68	0.13		
	008	3/16 x 5/16 x 1/16	.176	.005			4.47	0.13		
	009	7/32 x 11/32 x 1/16	.208	.005			5.28	0.13		
	010	1/4 x 3/8 x 1/16	.239	.005			6.07	0.13		
	011	5/16 x 7/16 x 1/16	.301	.005			7.65	0.13		
	012	3/8 x 1/2 x 1/16	.364	.005			9.25	0.13		
	013	7/16 x 9/16 x 1/16	.426	.005			10.82	0.13		
	014	1/2 x 5/8 x 1/16	.489	.005			12.42	0.13		
	015	9/16 x 11/16 x 1/16	.551	.007			14.00	0.18		
	016	5/8 x 3/4 x 1/16	.614	.009			15.60	0.23		
	017	11/16 x 13/16 x 1/16	.676	.009			17.17	0.23		
	018	3/4 x 7/8 x 1/16	.739	.009			18.77	0.23		
	019	13/16 x 15/16 x 1/16	.801	.009			20.35	0.23		
	020	7/8 x 1 x 1/16	.864	.009			21.95	0.23		
	021	15/16 x 11/16 x 1/16	.926	.009			23.52	0.23		
	022	1 x 1 1/8 x 1/16	.989	.010			25.12	0.25		
	023	1 1/16 x 1 3/16 x 1/16	1.051	.010			26.70	0.25		
	024	1 1/8 x 1 1/4 x 1/16	1.114	.010			28.30	0.25		
	025	1 3/16 x 1 5/16 x 1/16	1.176	.011			29.87	0.28		
	026	1 1/4 x 1 3/8 x 1/16	1.239	.011			31.47	0.28		
	027	1 5/16 x 1 7/16 x 1/16	1.301	.011			33.05	0.28		
	028	1 3/8 x 1 1/2 x 1/16	1.364	.013			34.65	0.33		
	029	1 1/2 x 1 5/8 x 1/16	1.489	.013			37.82	0.33		
	030	1 5/8 x 1 3/4 x 1/16	1.614	.013			41.00	0.33		
	031	1 3/4 x 1 7/8 x 1/16	1.739	.015			44.17	0.38		
	032	1 7/8 x 2 x 1/16	1.864	.015			47.35	0.38		
	033	2 x 2 1/8 x 1/16	1.989	.018			50.52	0.46		
	034	2 1/8 x 2 1/4 x 1/16	2.114	.018			53.70	0.46		
	035	2 1/4 x 2 3/8 x 1/16	2.239	.018			56.87	0.46		
	036	2 3/8 x 2 1/2 x 1/16	2.364	.018			60.05	0.46		
	037	2 1/2 x 2 5/8 x 1/16	2.489	.018			63.22	0.46		
	038	2 5/8 x 2 3/4 x 1/16	2.614	.020			66.40	0.51		
	039	2 3/4 x 2 7/8 x 1/16	2.739	.020			69.57	0.51		
	040	2 7/8 x 3 x 1/16	2.864	.020			72.75	0.51		
	041	3 x 3 1/8 x 1/16	2.989	.024			75.92	0.61		
	042	3 1/4 x 3 3/8 x 1/16	3.239	.024			82.27	0.61		
	043	3 1/2 x 3 5/8 x 1/16	3.489	.024			88.62	0.61		
	044	3 3/4 x 3 7/8 x 1/16	3.739	.027			94.97	0.69		
	045	4 x 4 1/8 x 1/16	3.989	.027			101.32	0.69		
	046	4 1/4 x 4 3/8 x 1/16	4.239	.027			107.67	0.76		
	047	4 1/2 x 4 5/8 x 1/16	4.489	.030			114.02	0.76		
	048	4 3/4 x 4 7/8 x 1/16	4.739	.030			120.37	0.76		
	049	5 x 5 1/8 x 1/16	4.989	.037			126.72	0.94		
	050	5 1/4 x 5 3/8 x 1/16	5.239	.037	.070	.003	133.07	0.94	1.78	0.08

Your Part Number	Newman Size Number	Nominal Size	INCH STANDARD				METRIC STANDARD			
			Inside Diameter		Cross Section W		Inside Diameter		Cross Section W	
			In.	±	In.	±	MM.	±	MM.	±
	102	1/16 x 1/4 x 3/32	.049	.005	.103	.003	1.24	0.10	2.62	0.08
	103	3/32 x 9/32 x 3/32	.081	.005			2.06	0.13		
	104	1/8 x 5/16 x 3/32	.112	.005			2.84	0.13		
	105	5/32 x 11/32 x 3/32	.143	.005			3.63	0.13		
	106	3/16 x 3/8 x 3/32	.174	.005			4.42	0.13		
	107	7/32 x 13/32 x 3/32	.206	.005			5.23	0.13		
	108	1/4 x 7/16 x 3/32	.237	.005			6.02	0.13		
	109	5/16 x 1/2 x 3/32	.299	.005			7.59	0.13		
	110	3/8 x 9/16 x 3/32	.362	.005			9.19	0.13		
	111	7/16 x 5/8 x 3/32	.424	.005			10.77	0.13		
	112	1/2 x 11/16 x 3/32	.487	.005			12.37	0.13		
	113	9/16 x 3/4 x 3/32	.549	.007			13.94	0.18		
	114	5/8 x 13/16 x 3/32	.612	.009			15.54	0.23		
	115	11/16 x 7/8 x 3/32	.674	.009			17.12	0.23		
	116	3/4 x 15/16 x 3/32	.737	.009			18.72	0.23		
	117	13/16 x 1 x 3/32	.799	.010			20.29	0.25		
	118	7/8 x 11/16 x 3/32	.862	.010			21.89	0.25		
	119	15/16 x 1 1/8 x 3/32	.924	.010			23.47	0.25		
	120	1 x 1 3/16 x 3/32	.987	.010			25.07	0.25		
	121	1 1/16 x 1 1/4 x 3/32	1.049	.010			26.64	0.25		
	122	1 1/8 x 1 5/16 x 3/32	1.112	.010			28.24	0.25		
	123	1 3/16 x 1 3/8 x 3/32	1.174	.012			29.82	0.30		
	124	1 1/4 x 1 7/16 x 3/32	1.237	.012			31.42	0.30		
	125	1 5/16 x 1 1/2 x 3/32	1.299	.012			32.99	0.30		
	126	1 3/8 x 1 9/16 x 3/32	1.362	.012			34.59	0.30		
	127	1 7/16 x 1 5/8 x 3/32	1.424	.012			36.17	0.30		
	128	1 1/2 x 1 11/16 x 3/32	1.487	.012			37.77	0.30		
	129	1 9/16 x 1 3/4 x 3/32	1.549	.015			39.34	0.38		
	130	1 5/8 x 1 13/16 x 3/32	1.612	.015			40.94	0.38		
	131	1 11/16 x 1 7/8 x 3/32	1.674	.015			42.52	0.38		
	132	1 3/4 x 1 15/16 x 3/32	1.737	.015			44.12	0.38		
	133	1 13/16 x 2 x 3/32	1.799	.015			45.69	0.38		
	134	1 7/8 x 2 1/16 x 3/32	1.862	.015			47.29	0.38		
	135	1 15/16 x 2 1/8 x 3/32	1.925	.017			48.90	0.43		
	136	2 x 2 3/16 x 3/32	1.987	.017			50.47	0.43		
	137	2 1/16 x 2 1/4 x 3/32	2.050	.017			52.07	0.43		
	138	2 1/8 x 2 5/16 x 3/32	2.112	.017			53.64	0.43		
	139	2 3/16 x 2 3/8 x 3/32	2.175	.017			55.25	0.43		
	140	2 1/4 x 2 7/16 x 3/32	2.237	.017			56.82	0.43		
	141	2 5/16 x 2 1/2 x 3/32	2.300	.020			58.42	0.51		
	142	2 3/8 x 2 9/16 x 3/32	2.362	.020			59.99	0.5		
	143	2 7/16 x 2 5/8 x 3/32	2.425	.020			61.60	0.51		
	144	2 1/2 x 2 11/16 x 3/32	2.487	.020			63.17	0.51		
	145	2 9/16 x 2 3/4 x 3/32	2.550	.020			64.77	0.51		
	146	2 5/8 x 2 13/16 x 3/32	2.612	.020			66.34	0.51		
	147	2 11/16 x 2 7/8 x 3/32	2.675	.022			67.95	0.56		
	148	2 3/4 x 2 15/16 x 3/32	2.737	.022			69.52	0.56		
	149	2 13/16 x 3 x 3/32	2.800	.022			71.12	0.56		
	150	2 7/8 x 3 1/16 x 3/32	2.862	.022			72.69	0.56		
	151	3 x 3 3/16 x 3/32	2.987	.024			75.87	0.61		
	152	3 1/4 x 3 7/16 x 3/32	3.237	.024	.103	.003	82.22	0.61	2.62	0.08

Your Part Number	Newman Size Number	Nominal Size	INCH STANDARD				METRIC STANDARD			
			Inside Diameter		Cross Section W		Inside Diameter		Cross Section W	
			In.	±	In.	±	MM.	±	MM.	±
	153	3½ x 3¹¹/₁₆ x ¾	3.487	.024	.103	.003	88.57	0.61	2.62	0.08
	154	3¾ x 3¹⁵/₁₆ x ¾	3.737	.028			94.92	0.71		
	155	4 x 4³/₁₆ x ¾	3.987	.028			101.27	0.71		
	156	4¼ x 4⁷/₁₆ x ¾	4.237	.030			107.62	0.76		
	157	4½ x 4¹¹/₁₆ x ¾	4.487	.030			113.97	0.76		
	158	4¾ x 4¹⁵/₁₆ x ¾	4.737	.030			120.32	0.76		
	159	5 x 5³/₁₆ x ¾	4.987	.035			126.67	0.89		
	160	5¼ x 5⁷/₁₆ x ¾	5.237	.035			133.02	0.89		
	161	5½ x 5¹¹/₁₆ x ¾	5.487	.035			139.37	0.89		
	162	5¾ x 5¹⁵/₁₆ x ¾	5.737	.035			145.72	0.89		
	163	6 x 6³/₁₆ x ¾	5.987	.035			152.07	0.89		
	164	6¼ x 6⁷/₁₆ x ¾	6.237	.040			158.42	1.02		
	165	6½ x 6¹¹/₁₆ x ¾	6.487	.040			164.77	1.02		
	166	6¾ x 6¹⁵/₁₆ x ¾	6.737	.040			171.12	1.02		
	167	7 x 7³/₁₆ x ¾	6.987	.040			177.47	1.02		
	168	7¼ x 7⁷/₁₆ x ¾	7.237	.045			183.82	1.14		
	169	7½ x 7¹¹/₁₆ x ¾	7.487	.045			190.17	1.14		
	170	7¾ x 7¹⁵/₁₆ x ¾	7.737	.045			196.54	1.14		
	171	8 x 8³/₁₆ x ¾	7.987	.045			202.87	1.14		
	172	8¼ x 8⁷/₁₆ x ¾	8.237	.050			209.22	1.27		
	173	8½ x 8¹¹/₁₆ x ¾	8.487	.050			215.57	1.27		
	174	8¾ x 8¹⁵/₁₆ x ¾	8.737	.050			221.92	1.27		
	175	9 x 9³/₁₆ x ¾	8.987	.050			228.27	1.27		
	176	9¼ x 9⁷/₁₆ x ¾	9.237	.055			234.62	1.40		
	177	9½ x 9¹¹/₁₆ x ¾	9.487	.055			240.97	1.40		
	178	9¾ x 9¹⁵/₁₆ x ¾	9.737	.055	.103	.003	247.32	1.40	2.62	0.08
	201	¾ x ⁷/₁₆ x ¹/₈	.171	.007	.139	.004	4.34	0.18	3.53	0.10
	202	¼ x ½ x ¹/₈	.234	.007			5.94	0.18		
	203	⁵/₁₆ x ⁹/₁₆ x ¹/₈	.296	.007			7.52	0.18		
	204	³/₈ x ⁵/₈ x ¹/₈	.359	.007			9.12	0.18		
	205	⁷/₁₆ x ¹¹/₁₆ x ¹/₈	.421	.007			10.69	0.18		
	206	½ x ¾ x ¹/₈	.484	.007			12.29	0.18		
	207	⁹/₁₆ x ¹³/₁₆ x ¹/₈	.546	.007			13.87	0.18		
	208	⁵/₈ x ⁷/₈ x ¹/₈	.609	.009			15.47	0.23		
	209	¹¹/₁₆ x ¹⁵/₁₆ x ¹/₈	.671	.009			17.04	0.23		
	210	¾ x 1 x ¹/₈	.734	.010			18.66	0.25		
	211	¹³/₁₆ x 1¹/₁₆ x ¹/₈	.796	.010			20.22	0.25		
	212	⁷/₈ x 1¹/₈ x ¹/₈	.859	.010			21.82	0.25		
	213	¹⁵/₁₆ x 1³/₁₆ x ¹/₈	.921	.010			23.40	0.25		
	214	1 x 1¼ x ¹/₈	.984	.010			25.00	0.25		
	215	1¹/₁₆ x 1⁵/₁₆ x ¹/₈	1.046	.010			26.58	0.25		
	216	1¹/₈ x 1³/₈ x ¹/₈	1.109	.012			28.17	0.30		
	217	1³/₁₆ x 1⁷/₁₆ x ¹/₈	1.171	.012			29.75	0.30		
	218	1¼ x 1½ x ¹/₈	1.234	.012			31.35	0.30		
	219	1⁵/₁₆ x 1⁹/₁₆ x ¹/₈	1.296	.012			32.92	0.30		
	220	1³/₈ x 1⁵/₈ x ¹/₈	1.359	.012			34.52	0.30		
	221	1⁷/₁₆ x 1¹¹/₁₆ x ¹/₈	1.421	.012			36.09	0.30		
	222	1½ x 1¾ x ¹/₈	1.484	.015			37.70	0.38		
	223	1⁵/₈ x 1⁷/₈ x ¹/₈	1.609	.015	.139	.004	40.87	0.38	3.53	0.10

Your Part Number	Newman Size Number	Nominal Size	INCH STANDARD				METRIC STANDARD			
			Inside Diameter		Cross Section W		Inside Diameter		Cross Section W	
			In.	±	In.	±	MM.	±	MM.	±
	224	1 <sup>3</sup> / <sub>4</sub> x 2 x 1 <sup>1</sup> / <sub>8</sub>	1.734	.015	.139	.004	44.04	0.38	3.53	0.10
	225	1 <sup>7</sup> / <sub>8</sub> x 2 <sup>1</sup> / <sub>8</sub> x 1 <sup>1</sup> / <sub>8</sub>	1.859	.018			47.22	0.46		
	226	2 x 2 <sup>1</sup> / <sub>4</sub> x 1 <sup>1</sup> / <sub>8</sub>	1.984	.018			50.39	0.46		
	227	2 <sup>1</sup> / <sub>8</sub> x 2 <sup>3</sup> / <sub>8</sub> x 1 <sup>1</sup> / <sub>8</sub>	2.109	.018			53.57	0.46		
	228	2 <sup>1</sup> / <sub>4</sub> x 2 <sup>1</sup> / <sub>2</sub> x 1 <sup>1</sup> / <sub>8</sub>	2.234	.020			56.74	0.51		
	229	2 <sup>3</sup> / <sub>8</sub> x 2 <sup>5</sup> / <sub>8</sub> x 1 <sup>1</sup> / <sub>8</sub>	2.359	.020			59.92	0.51		
	230	2 <sup>1</sup> / <sub>2</sub> x 2 <sup>3</sup> / <sub>4</sub> x 1 <sup>1</sup> / <sub>8</sub>	2.484	.020			63.09	0.51		
	231	2 <sup>5</sup> / <sub>8</sub> x 2 <sup>7</sup> / <sub>8</sub> x 1 <sup>1</sup> / <sub>8</sub>	2.609	.020			66.27	0.51		
	232	2 <sup>3</sup> / <sub>4</sub> x 3 x 1 <sup>1</sup> / <sub>8</sub>	2.734	.024			69.44	0.61		
	233	2 <sup>7</sup> / <sub>8</sub> x 3 <sup>1</sup> / <sub>8</sub> x 1 <sup>1</sup> / <sub>8</sub>	2.859	.024			72.62	0.61		
	234	3 x 3 <sup>1</sup> / <sub>4</sub> x 1 <sup>1</sup> / <sub>8</sub>	2.984	.024			75.79	0.61		
	235	3 <sup>1</sup> / <sub>8</sub> x 3 <sup>3</sup> / <sub>8</sub> x 1 <sup>1</sup> / <sub>8</sub>	3.109	.024			78.97	0.61		
	236	3 <sup>1</sup> / <sub>4</sub> x 3 <sup>1</sup> / <sub>2</sub> x 1 <sup>1</sup> / <sub>8</sub>	3.234	.024			82.14	0.61		
	237	3 <sup>3</sup> / <sub>8</sub> x 3 <sup>5</sup> / <sub>8</sub> x 1 <sup>1</sup> / <sub>8</sub>	3.359	.024			85.32	0.61		
	238	3 <sup>1</sup> / <sub>2</sub> x 3 <sup>3</sup> / <sub>4</sub> x 1 <sup>1</sup> / <sub>8</sub>	3.484	.024			88.49	0.61		
	239	3 <sup>5</sup> / <sub>8</sub> x 3 <sup>7</sup> / <sub>8</sub> x 1 <sup>1</sup> / <sub>8</sub>	3.609	.028			91.67	0.71		
	240	3 <sup>3</sup> / <sub>4</sub> x 4 x 1 <sup>1</sup> / <sub>8</sub>	3.734	.028			94.84	0.71		
	241	3 <sup>7</sup> / <sub>8</sub> x 4 <sup>1</sup> / <sub>8</sub> x 1 <sup>1</sup> / <sub>8</sub>	3.859	.028			98.02	0.71		
	242	4 x 4 <sup>1</sup> / <sub>4</sub> x 1 <sup>1</sup> / <sub>8</sub>	3.984	.028			101.19	0.71		
	243	4 <sup>1</sup> / <sub>8</sub> x 4 <sup>3</sup> / <sub>8</sub> x 1 <sup>1</sup> / <sub>8</sub>	4.109	.028			104.37	0.71		
	244	4 <sup>1</sup> / <sub>4</sub> x 4 <sup>1</sup> / <sub>2</sub> x 1 <sup>1</sup> / <sub>8</sub>	4.234	.030			107.54	0.76		
	245	4 <sup>3</sup> / <sub>8</sub> x 4 <sup>5</sup> / <sub>8</sub> x 1 <sup>1</sup> / <sub>8</sub>	4.359	.030			110.72	0.76		
	246	4 <sup>1</sup> / <sub>2</sub> x 4 <sup>3</sup> / <sub>4</sub> x 1 <sup>1</sup> / <sub>8</sub>	4.484	.030			113.89	0.76		
	247	4 <sup>5</sup> / <sub>8</sub> x 4 <sup>7</sup> / <sub>8</sub> x 1 <sup>1</sup> / <sub>8</sub>	4.609	.030			117.07	0.76		
	248	4 <sup>3</sup> / <sub>4</sub> x 5 x 1 <sup>1</sup> / <sub>8</sub>	4.734	.030			120.24	0.76		
	249	4 <sup>7</sup> / <sub>8</sub> x 5 <sup>1</sup> / <sub>8</sub> x 1 <sup>1</sup> / <sub>8</sub>	4.859	.035			123.42	0.89		
	250	5 x 5 <sup>1</sup> / <sub>4</sub> x 1 <sup>1</sup> / <sub>8</sub>	4.984	.035			126.59	0.89		
	251	5 <sup>1</sup> / <sub>8</sub> x 5 <sup>3</sup> / <sub>8</sub> x 1 <sup>1</sup> / <sub>8</sub>	5.109	.035			129.77	0.89		
	252	5 <sup>1</sup> / <sub>4</sub> x 5 <sup>1</sup> / <sub>2</sub> x 1 <sup>1</sup> / <sub>8</sub>	5.234	.035			132.94	0.89		
	253	5 <sup>3</sup> / <sub>8</sub> x 5 <sup>5</sup> / <sub>8</sub> x 1 <sup>1</sup> / <sub>8</sub>	5.359	.035			136.12	0.89		
	254	5 <sup>1</sup> / <sub>2</sub> x 5 <sup>3</sup> / <sub>4</sub> x 1 <sup>1</sup> / <sub>8</sub>	5.484	.035			139.29	0.89		
	255	5 <sup>5</sup> / <sub>8</sub> x 5 <sup>7</sup> / <sub>8</sub> x 1 <sup>1</sup> / <sub>8</sub>	5.609	.035			142.47	0.89		
	256	5 <sup>3</sup> / <sub>4</sub> x 6 x 1 <sup>1</sup> / <sub>8</sub>	5.734	.035			145.64	0.89		
	257	5 <sup>7</sup> / <sub>8</sub> x 6 <sup>1</sup> / <sub>8</sub> x 1 <sup>1</sup> / <sub>8</sub>	5.859	.035			148.82	0.89		
	258	6 x 6 <sup>1</sup> / <sub>4</sub> x 1 <sup>1</sup> / <sub>8</sub>	5.984	.035			151.99	0.89		
	259	6 <sup>1</sup> / <sub>4</sub> x 6 <sup>1</sup> / <sub>2</sub> x 1 <sup>1</sup> / <sub>8</sub>	6.234	.040			158.34	1.02		
	260	6 <sup>1</sup> / <sub>2</sub> x 6 <sup>3</sup> / <sub>4</sub> x 1 <sup>1</sup> / <sub>8</sub>	6.484	.040			164.69	1.02		
	261	6 <sup>3</sup> / <sub>4</sub> x 7 x 1 <sup>1</sup> / <sub>8</sub>	6.734	.040			171.04	1.02		
	262	7 x 7 <sup>1</sup> / <sub>4</sub> x 1 <sup>1</sup> / <sub>8</sub>	6.984	.040			177.39	1.02		
	263	7 <sup>1</sup> / <sub>4</sub> x 7 <sup>1</sup> / <sub>2</sub> x 1 <sup>1</sup> / <sub>8</sub>	7.234	.045			183.74	1.14		
	264	7 <sup>1</sup> / <sub>2</sub> x 7 <sup>3</sup> / <sub>4</sub> x 1 <sup>1</sup> / <sub>8</sub>	7.484	.045			190.09	1.14		
	265	7 <sup>3</sup> / <sub>4</sub> x 8 x 1 <sup>1</sup> / <sub>8</sub>	7.734	.045			196.44	1.14		
	266	8 x 8 <sup>1</sup> / <sub>4</sub> x 1 <sup>1</sup> / <sub>8</sub>	7.984	.045			202.79	1.14		
	267	8 <sup>1</sup> / <sub>4</sub> x 8 <sup>1</sup> / <sub>2</sub> x 1 <sup>1</sup> / <sub>8</sub>	8.234	.050			209.14	1.27		
	268	8 <sup>1</sup> / <sub>2</sub> x 8 <sup>3</sup> / <sub>4</sub> x 1 <sup>1</sup> / <sub>8</sub>	8.484	.050			215.49	1.27		
	269	8 <sup>3</sup> / <sub>4</sub> x 9 x 1 <sup>1</sup> / <sub>8</sub>	8.734	.050			221.84	1.27		
	270	9 x 9 <sup>1</sup> / <sub>4</sub> x 1 <sup>1</sup> / <sub>8</sub>	8.984	.050			228.19	1.27		
	271	9 <sup>1</sup> / <sub>4</sub> x 9 <sup>1</sup> / <sub>2</sub> x 1 <sup>1</sup> / <sub>8</sub>	9.234	.055			234.54	1.40		
	272	9 <sup>1</sup> / <sub>2</sub> x 9 <sup>3</sup> / <sub>4</sub> x 1 <sup>1</sup> / <sub>8</sub>	9.484	.055			240.89	1.40		
	273	9 <sup>3</sup> / <sub>4</sub> x 10 x 1 <sup>1</sup> / <sub>8</sub>	9.734	.055			247.24	1.40		
	274	10 x 10 <sup>1</sup> / <sub>4</sub> x 1 <sup>1</sup> / <sub>8</sub>	9.984	.055	.139	.004	253.59	1.40	3.53	0.10

Your Part Number	Newman Size Number	Nominal Size	INCH STANDARD				METRIC STANDARD			
			Inside Diameter		Cross Section W		Inside Diameter		Cross Section W	
			In.	±	In.	±	MM.	±	MM.	±
	275	10½ x 10¾ x ⅛	10.484	.055	.139	.004	266.29	1.40	3.53	0.10
	276	11 x 11¼ x ⅛	10.984	.065			278.99	1.65		
	277	11½ x 11¾ x ⅛	11.484	.065			291.69	1.65		
	278	12 x 12¼ x ⅛	11.984	.065			304.39	1.65		
	279	13 x 13¼ x ⅛	12.984	.065			329.79	1.65		
	280	14 x 14¼ x ⅛	13.984	.065			355.19	1.65		
	281	15 x 15¼ x ⅛	14.984	.065			380.59	1.65		
	282	16 x 16¼ x ⅛	15.955	.075			405.26	1.90		
	283	17 x 17¼ x ⅛	16.955	.080			430.66	2.16		
	284	18 x 18¼ x ⅛	17.955	.085	.139	.004	456.06	2.42	3.53	0.10
	309	7/16 x 13/16 x 3/16	.412	.005	.210	.005	10.46	0.13	5.33	0.13
	310	½ x 7/8 x 3/16	.475	.005			12.07	0.13		
	311	9/16 x 15/16 x 3/16	.537	.007			13.64	0.18		
	312	5/8 x 1 x 3/16	.600	.009			15.25	0.23		
	313	11/16 x 11/16 x 3/16	.662	.009			16.81	0.23		
	314	¾ x 1⅛ x 3/16	.725	.010			18.42	0.25		
	315	13/16 x 13/16 x 3/16	.787	.010			19.99	0.25		
	316	7/8 x 1¼ x 3/16	.850	.010			21.59	0.25		
	317	15/16 x 15/16 x 3/16	.912	.010			23.16	0.25		
	318	1 x 1⅜ x 3/16	.975	.010			24.77	0.25		
	319	11/16 x 17/16 x 3/16	1.037	.010			26.34	0.25		
	320	1⅛ x 1½ x 3/16	1.100	.012			27.94	0.30		
	321	13/16 x 19/16 x 3/16	1.162	.012			29.51	0.30		
	322	1¼ x 15/8 x 3/16	1.225	.012			31.12	0.30		
	323	15/16 x 111/16 x 3/16	1.287	.012			32.69	0.30		
	324	13/8 x 1¾ x 3/16	1.350	.012			34.29	0.30		
	325	11/12 x 17/8 x 3/16	1.475	.015			37.47	0.38		
	326	15/8 x 2 x 3/16	1.600	.015			40.64	0.38		
	327	1¾ x 2⅛ x 3/16	1.725	.015			43.82	0.38		
	328	17/8 x 2¼ x 3/16	1.850	.015			46.99	0.38		
	329	2 x 2⅜ x 3/16	1.975	.018			50.17	0.46		
	330	2⅛ x 2½ x 3/16	2.100	.018			53.34	0.46		
	331	2¼ x 25/8 x 3/16	2.225	.018			56.52	0.46		
	332	23/8 x 2¾ x 3/16	2.350	.018			59.69	0.46		
	333	2½ x 27/8 x 3/16	2.475	.020			62.87	0.51		
	334	25/8 x 3 x 3/16	2.600	.020			66.04	0.51		
	335	2¾ x 31/8 x 3/16	2.725	.020			69.22	0.51		
	336	27/8 x 3¼ x 3/16	2.850	.020			72.39	0.51		
	337	3 x 33/8 x 3/16	2.975	.024			75.57	0.61		
	338	31/8 x 3½ x 3/16	3.100	.024			78.74	0.61		
	339	3¼ x 35/8 x 3/16	3.225	.024			81.92	0.61		
	340	33/8 x 3¾ x 3/16	3.350	.024			85.09	0.61		
	341	3½ x 37/8 x 3/16	3.475	.024			88.27	0.61		
	342	35/8 x 4 x 3/16	3.600	.028			91.44	0.71		
	343	3¾ x 4⅛ x 3/16	3.725	.028			94.62	0.71		
	344	37/8 x 4¼ x 3/16	3.850	.028			97.79	0.71		
	345	4 x 43/8 x 3/16	3.975	.028			100.97	0.71		
	346	4⅛ x 4½ x 3/16	4.100	.028	.210	.005	104.14	0.71	5.33	0.13



Your Part Number	Newman Size Number	Nominal Size	INCH STANDARD				METRIC STANDARD			
			Inside Diameter		Cross Section W		Inside Diameter		Cross Section W	
			In.	±	In.	±	MM.	±	MM.	±
	347	4 <sup>1</sup> / <sub>4</sub> x 4 <sup>5</sup> / <sub>8</sub> x 3 <sup>3</sup> / <sub>16</sub>	4.225	.030	.210	.005	107.32	0.76	5.33	0.13
	348	4 <sup>3</sup> / <sub>8</sub> x 4 <sup>3</sup> / <sub>4</sub> x 3 <sup>3</sup> / <sub>16</sub>	4.350	.030			110.49	0.76		
	349	4 <sup>1</sup> / <sub>2</sub> x 4 <sup>7</sup> / <sub>8</sub> x 3 <sup>3</sup> / <sub>16</sub>	4.475	.030			113.67	0.76		
	350	4 <sup>5</sup> / <sub>8</sub> x 5 x 3 <sup>3</sup> / <sub>16</sub>	4.600	.030			116.84	0.76		
	351	4 <sup>3</sup> / <sub>4</sub> x 5 <sup>1</sup> / <sub>8</sub> x 3 <sup>3</sup> / <sub>16</sub>	4.725	.030			120.02	0.76		
	352	4 <sup>7</sup> / <sub>8</sub> x 5 <sup>1</sup> / <sub>4</sub> x 3 <sup>3</sup> / <sub>16</sub>	4.850	.030			123.19	0.76		
	353	5 x 5 <sup>3</sup> / <sub>8</sub> x 3 <sup>3</sup> / <sub>16</sub>	4.975	.037			126.37	0.94		
	354	5 <sup>1</sup> / <sub>8</sub> x 5 <sup>1</sup> / <sub>2</sub> x 3 <sup>3</sup> / <sub>16</sub>	5.100	.037			129.54	0.94		
	355	5 <sup>1</sup> / <sub>4</sub> x 5 <sup>5</sup> / <sub>8</sub> x 3 <sup>3</sup> / <sub>16</sub>	5.225	.037			132.72	0.94		
	356	5 <sup>3</sup> / <sub>8</sub> x 5 <sup>3</sup> / <sub>4</sub> x 3 <sup>3</sup> / <sub>16</sub>	5.350	.037			135.89	0.94		
	357	5 <sup>1</sup> / <sub>2</sub> x 5 <sup>7</sup> / <sub>8</sub> x 3 <sup>3</sup> / <sub>16</sub>	5.475	.037			139.07	0.94		
	358	5 <sup>5</sup> / <sub>8</sub> x 6 x 3 <sup>3</sup> / <sub>16</sub>	5.600	.037			142.24	0.94		
	359	5 <sup>3</sup> / <sub>4</sub> x 6 <sup>1</sup> / <sub>8</sub> x 3 <sup>3</sup> / <sub>16</sub>	5.725	.037			145.42	0.94		
	360	5 <sup>7</sup> / <sub>8</sub> x 6 <sup>1</sup> / <sub>4</sub> x 3 <sup>3</sup> / <sub>16</sub>	5.850	.037			148.49	0.94		
	361	6 x 6 <sup>3</sup> / <sub>8</sub> x 3 <sup>3</sup> / <sub>16</sub>	5.975	.037			151.77	0.94		
	362	6 <sup>1</sup> / <sub>4</sub> x 6 <sup>5</sup> / <sub>8</sub> x 3 <sup>3</sup> / <sub>16</sub>	6.225	.040			158.12	1.02		
	363	6 <sup>1</sup> / <sub>2</sub> x 6 <sup>7</sup> / <sub>8</sub> x 3 <sup>3</sup> / <sub>16</sub>	6.475	.040			164.47	1.02		
	364	6 <sup>3</sup> / <sub>4</sub> x 7 <sup>1</sup> / <sub>8</sub> x 3 <sup>3</sup> / <sub>16</sub>	6.725	.040			170.82	1.02		
	365	7 x 7 <sup>3</sup> / <sub>8</sub> x 3 <sup>3</sup> / <sub>16</sub>	6.975	.040			177.17	1.02		
	366	7 <sup>1</sup> / <sub>4</sub> x 7 <sup>5</sup> / <sub>8</sub> x 3 <sup>3</sup> / <sub>16</sub>	7.225	.045			183.52	1.14		
	367	7 <sup>1</sup> / <sub>2</sub> x 7 <sup>7</sup> / <sub>8</sub> x 3 <sup>3</sup> / <sub>16</sub>	7.475	.045			189.87	1.14		
	368	7 <sup>3</sup> / <sub>4</sub> x 8 <sup>1</sup> / <sub>8</sub> x 3 <sup>3</sup> / <sub>16</sub>	7.725	.045			196.22	1.14		
	369	8 x 8 <sup>3</sup> / <sub>8</sub> x 3 <sup>3</sup> / <sub>16</sub>	7.975	.045			202.57	1.14		
	370	8 <sup>1</sup> / <sub>4</sub> x 8 <sup>5</sup> / <sub>8</sub> x 3 <sup>3</sup> / <sub>16</sub>	8.225	.050			208.92	1.30		
	371	8 <sup>1</sup> / <sub>2</sub> x 8 <sup>7</sup> / <sub>8</sub> x 3 <sup>3</sup> / <sub>16</sub>	8.475	.050			215.27	1.30		
	372	8 <sup>3</sup> / <sub>4</sub> x 9 <sup>1</sup> / <sub>8</sub> x 3 <sup>3</sup> / <sub>16</sub>	8.725	.050			221.65	1.30		
	373	9 x 9 <sup>3</sup> / <sub>8</sub> x 3 <sup>3</sup> / <sub>16</sub>	8.975	.050			227.97	1.30		
	374	9 <sup>1</sup> / <sub>4</sub> x 9 <sup>5</sup> / <sub>8</sub> x 3 <sup>3</sup> / <sub>16</sub>	9.225	.055			234.32	1.40		
	375	9 <sup>1</sup> / <sub>2</sub> x 9 <sup>7</sup> / <sub>8</sub> x 3 <sup>3</sup> / <sub>16</sub>	9.475	.055			240.67	1.40		
	376	9 <sup>3</sup> / <sub>4</sub> x 10 <sup>1</sup> / <sub>8</sub> x 3 <sup>3</sup> / <sub>16</sub>	9.725	.055			247.02	1.40		
	377	10 x 10 <sup>3</sup> / <sub>8</sub> x 3 <sup>3</sup> / <sub>16</sub>	9.975	.055			253.37	1.40		
	378	10 <sup>1</sup> / <sub>2</sub> x 10 <sup>7</sup> / <sub>8</sub> x 3 <sup>3</sup> / <sub>16</sub>	10.475	.060			266.07	1.52		
	379	11 x 11 <sup>3</sup> / <sub>8</sub> x 3 <sup>3</sup> / <sub>16</sub>	10.975	.060			278.77	1.52		
	380	11 <sup>1</sup> / <sub>2</sub> x 11 <sup>7</sup> / <sub>8</sub> x 3 <sup>3</sup> / <sub>16</sub>	11.475	.065			291.47	1.65		
	381	12 x 12 <sup>3</sup> / <sub>8</sub> x 3 <sup>3</sup> / <sub>16</sub>	11.975	.065			304.17	1.65		
	382	13 x 13 <sup>3</sup> / <sub>8</sub> x 3 <sup>3</sup> / <sub>16</sub>	12.975	.065			329.57	1.65		
	383	14 x 14 <sup>3</sup> / <sub>8</sub> x 3 <sup>3</sup> / <sub>16</sub>	13.975	.070			354.97	1.78		
	384	15 x 15 <sup>3</sup> / <sub>8</sub> x 3 <sup>3</sup> / <sub>16</sub>	14.975	.070			380.37	1.78		
	385	16 x 16 <sup>3</sup> / <sub>8</sub> x 3 <sup>3</sup> / <sub>16</sub>	15.955	.075			405.26	1.90		
	386	17 x 17 <sup>3</sup> / <sub>8</sub> x 3 <sup>3</sup> / <sub>16</sub>	16.955	.080			430.66	2.03		
	387	18 x 18 <sup>3</sup> / <sub>8</sub> x 3 <sup>3</sup> / <sub>16</sub>	17.955	.085			456.06	2.16		
	388	19 x 19 <sup>3</sup> / <sub>8</sub> x 3 <sup>3</sup> / <sub>16</sub>	18.952	.090			481.38	2.29		
	389	20 x 20 <sup>3</sup> / <sub>8</sub> x 3 <sup>3</sup> / <sub>16</sub>	19.952	.090			506.78	2.41		
	390	21 x 21 <sup>3</sup> / <sub>8</sub> x 3 <sup>3</sup> / <sub>16</sub>	20.952	.090			532.18	2.41		
	391	22 x 22 <sup>3</sup> / <sub>8</sub> x 3 <sup>3</sup> / <sub>16</sub>	21.952	.100			557.58	2.55		
	392	23 x 23 <sup>3</sup> / <sub>8</sub> x 3 <sup>3</sup> / <sub>16</sub>	22.940	.105			582.68	2.75		
	393	24 x 24 <sup>3</sup> / <sub>8</sub> x 3 <sup>3</sup> / <sub>16</sub>	23.940	.110			608.08	2.80		
	394	25 x 25 <sup>3</sup> / <sub>8</sub> x 3 <sup>3</sup> / <sub>16</sub>	24.940	.115			633.48	2.90		
	395	26 x 26 <sup>3</sup> / <sub>8</sub> x 3 <sup>3</sup> / <sub>16</sub>	25.940	.120	.210	.005	658.88	3.05	5.33	0.13

Your Part Number	Newman Size Number	Nominal Size	INCH STANDARD				METRIC STANDARD			
			Inside Diameter		Cross Section W		Inside Diameter		Cross Section W	
			In.	±	In.	±	MM.	±	MM.	±
	425	4½ x 5 x ¼	4.475	.033	.275	.006	113.67	0.84	6.99	0.15
	426	4⅝ x 5⅝ x ¼	4.600	.033			116.84	0.84		
	427	4¾ x 5¼ x ¼	4.725	.033			120.02	0.84		
	428	4⅞ x 5⅜ x ¼	4.850	.033			123.19	0.84		
	429	5 x 5½ x ¼	4.975	.037			126.37	0.94		
	430	5⅛ x 5⅝ x ¼	5.100	.037			129.54	0.94		
	431	5¼ x 5¾ x ¼	5.225	.037			132.72	0.94		
	432	5⅜ x 5⅞ x ¼	5.350	.037			135.89	0.94		
	433	5½ x 6 x ¼	5.475	.037			139.07	0.94		
	434	5⅝ x 6⅛ x ¼	5.600	.037			142.24	0.94		
	435	5¾ x 6¼ x ¼	5.725	.037			145.42	0.94		
	436	5⅞ x 6⅜ x ¼	5.850	.037			148.59	0.94		
	437	6 x 6½ x ¼	5.975	.037			151.77	0.94		
	438	6¼ x 6¾ x ¼	6.225	.040			158.12	1.02		
	439	6½ x 7 x ¼	6.475	.040			164.47	1.02		
	440	6¾ x 7¼ x ¼	6.725	.040			170.82	1.02		
	441	7 x 7½ x ¼	6.975	.040			177.17	1.02		
	442	7¼ x 7¾ x ¼	7.225	.045			183.52	1.14		
	443	7½ x 8 x ¼	7.475	.045			189.87	1.14		
	444	7¾ x 8¼ x ¼	7.725	.045			196.22	1.14		
	445	8 x 8½ x ¼	7.975	.045			202.57	1.14		
	446	8½ x 9 x ¼	8.475	.055			215.27	1.40		
	447	9 x 9½ x ¼	8.975	.055			227.97	1.40		
	448	9½ x 10 x ¼	9.475	.055			240.67	1.40		
	449	10 x 10½ x ¼	9.975	.055			253.37	1.40		
	450	10½ x 11 x ¼	10.475	.060			266.07	1.52		
	451	11 x 11½ x ¼	10.975	.060			278.77	1.52		
	452	11½ x 12 x ¼	11.475	.060			291.47	1.52		
	453	12 x 12½ x ¼	11.975	.060			304.17	1.52		
	454	12½ x 13 x ¼	12.475	.060			316.87	1.52		
	455	13 x 13½ x ¼	12.975	.060			329.57	1.52		
	456	13½ x 14 x ¼	13.475	.070			342.27	1.78		
	457	14 x 14½ x ¼	13.975	.070			354.97	1.78		
	458	14½ x 15 x ¼	14.475	.070			367.67	1.78		
	459	15 x 15½ x ¼	14.975	.070			380.37	1.78		
	460	15½ x 16 x ¼	15.475	.070			393.07	1.78		
	461	16 x 16½ x ¼	15.955	.075			405.26	1.90		
	462	16½ x 17 x ¼	16.455	.075			417.96	1.90		
	463	17 x 17½ x ¼	16.955	.080			430.66	2.05		
	464	17½ x 18 x ¼	17.455	.085			443.36	2.15		
	465	18 x 18½ x ¼	17.955	.085			456.06	2.15		
	466	18½ x 19 x ¼	18.455	.085			468.76	2.15		
	467	19 x 19½ x ¼	18.955	.090			481.46	2.29		
	468	19½ x 20 x ¼	19.455	.090			494.16	2.29		
	469	20 x 20½ x ¼	19.955	.090			506.86	2.41		
	470	21 x 21½ x ¼	20.955	.090			532.26	2.41		
	471	22 x 22½ x ¼	21.955	.100			557.66	2.55		
	472	23 x 23½ x ¼	22.940	.105			582.68	2.65		
	473	24 x 24½ x ¼	23.940	.110			608.08	2.80		
	474	25 x 25½ x ¼	24.940	.115			633.48	2.90		
	475	26 x 26½ x ¼	25.940	.120	.275	.006	658.88	3.05	6.99	0.15

**ADDITIONAL CROSS REFERENCE SPACE**

<b>Your Number</b>	<b>Newman Number</b>	<b>Your Number</b>	<b>Newman Number</b>	<b>Your Number</b>	<b>Newman Number</b>

000 SERIES -- .070 cross section

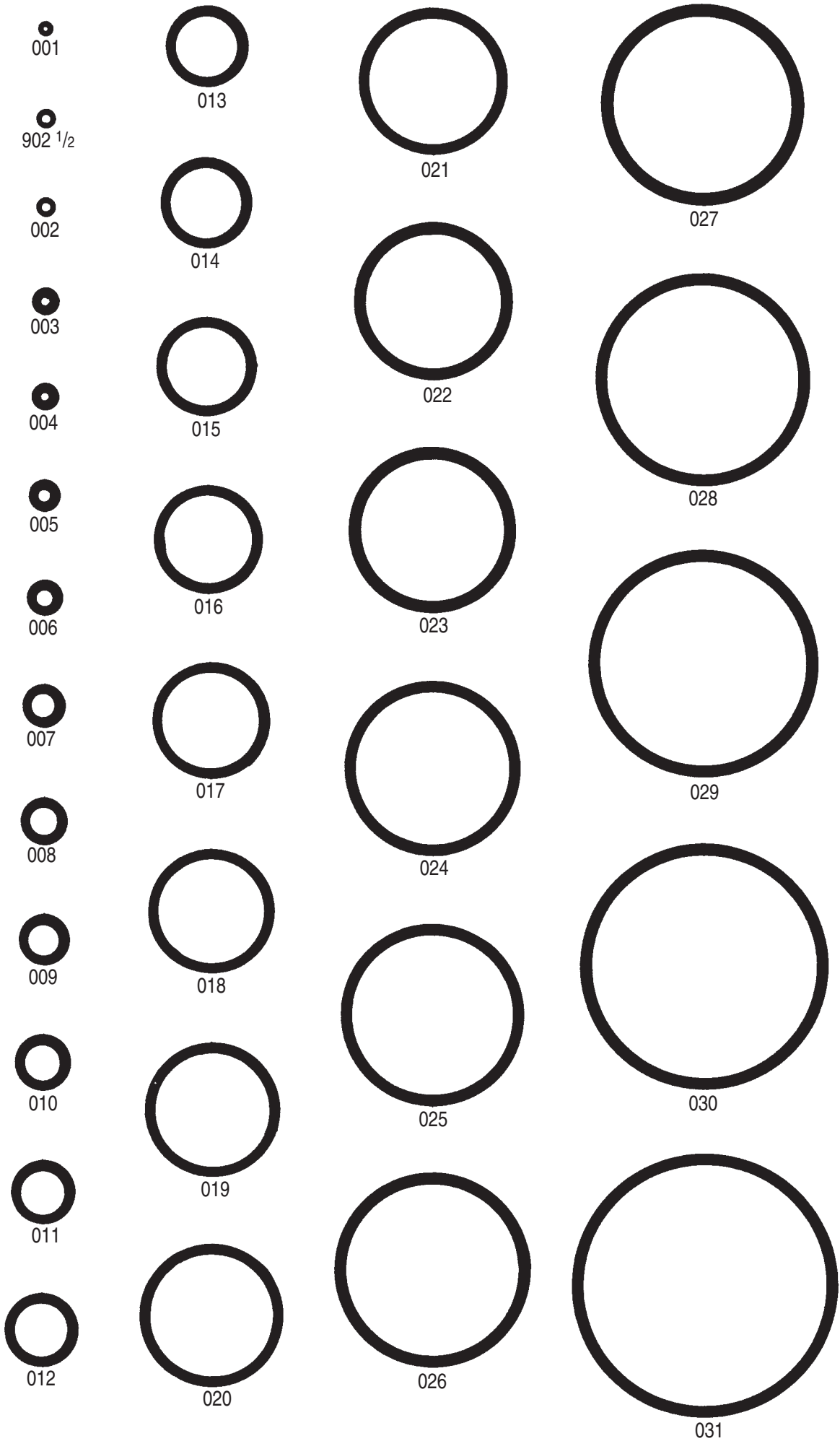

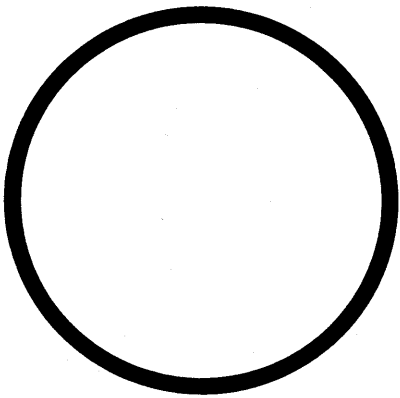

032

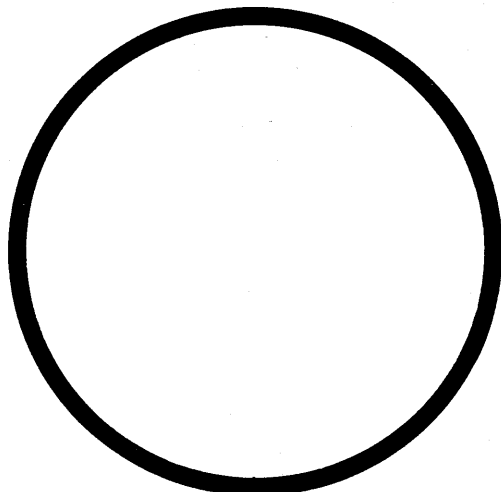

036

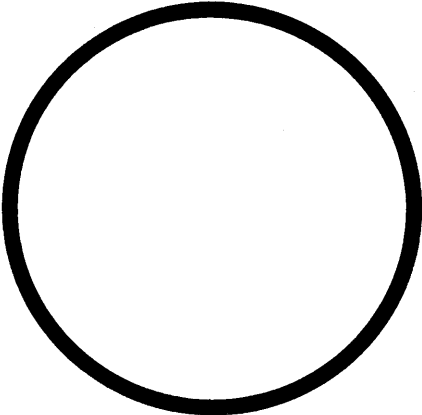

033

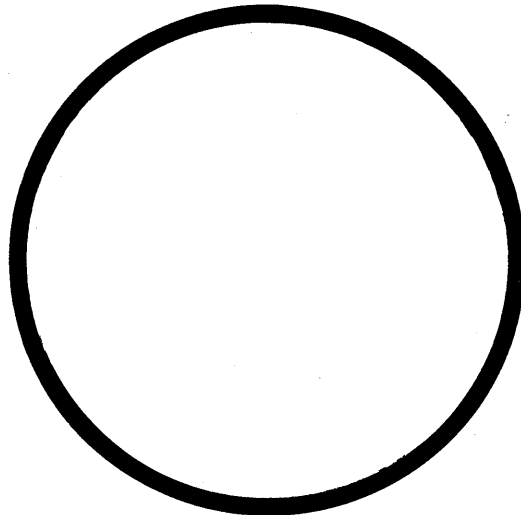

037

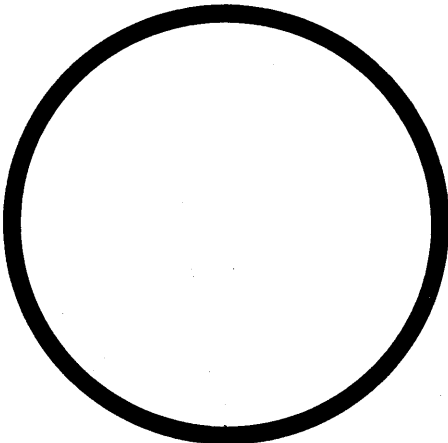

034

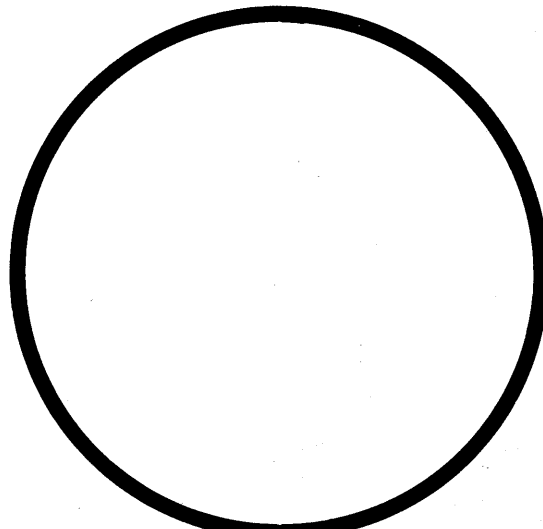

038

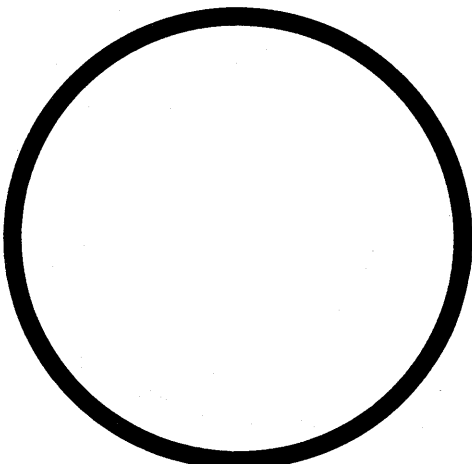

035

000 SERIES -- .070 cross section

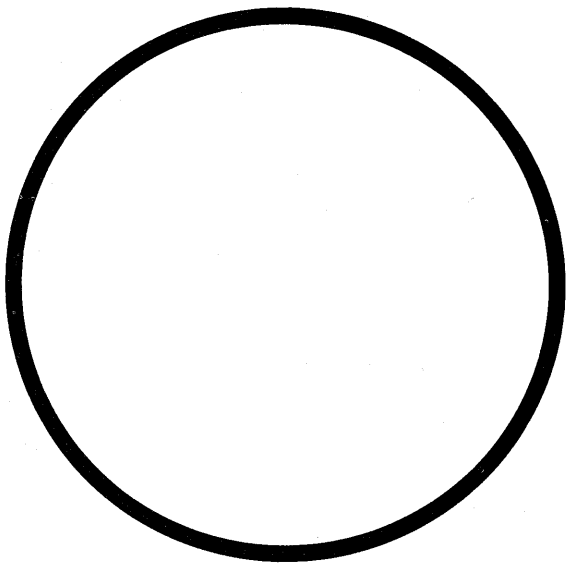

039

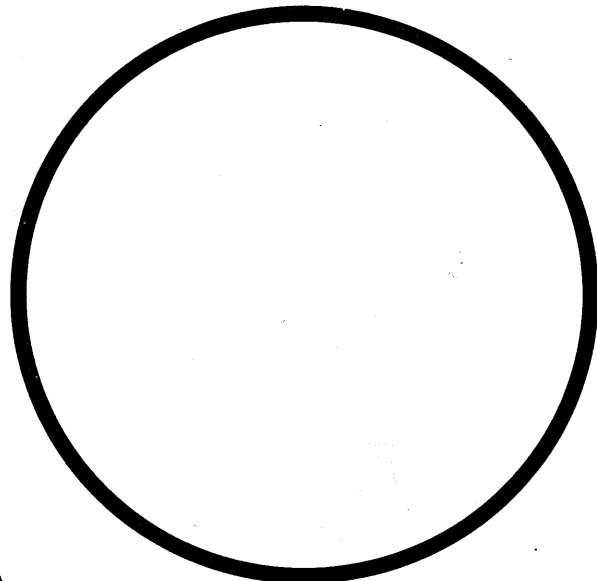

040

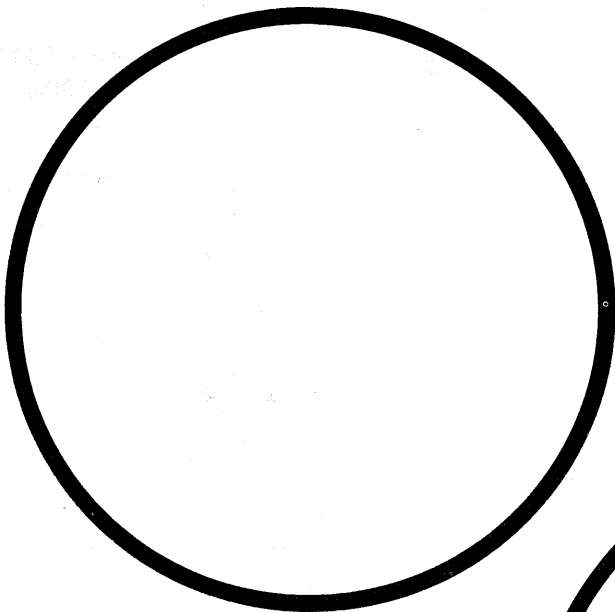

041

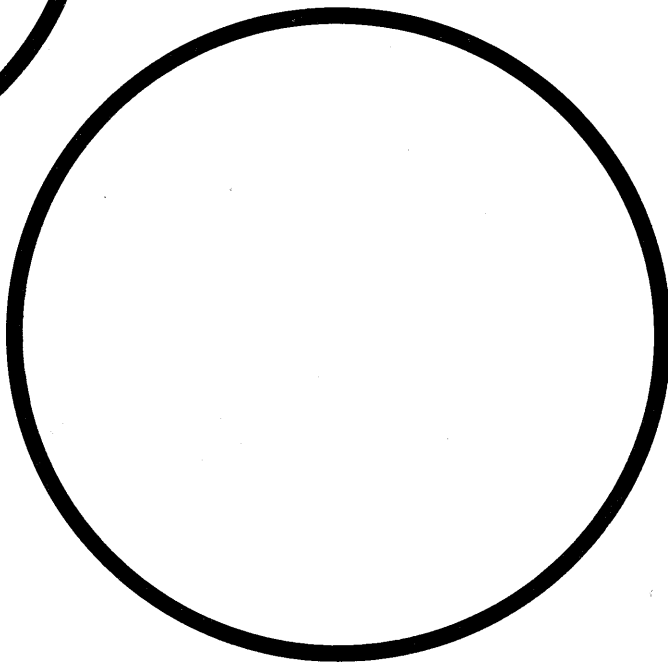

042

000 SERIES

043

045

047

049

000 SERIES IS SPACED IN TWO NUMBER INCREMENTS

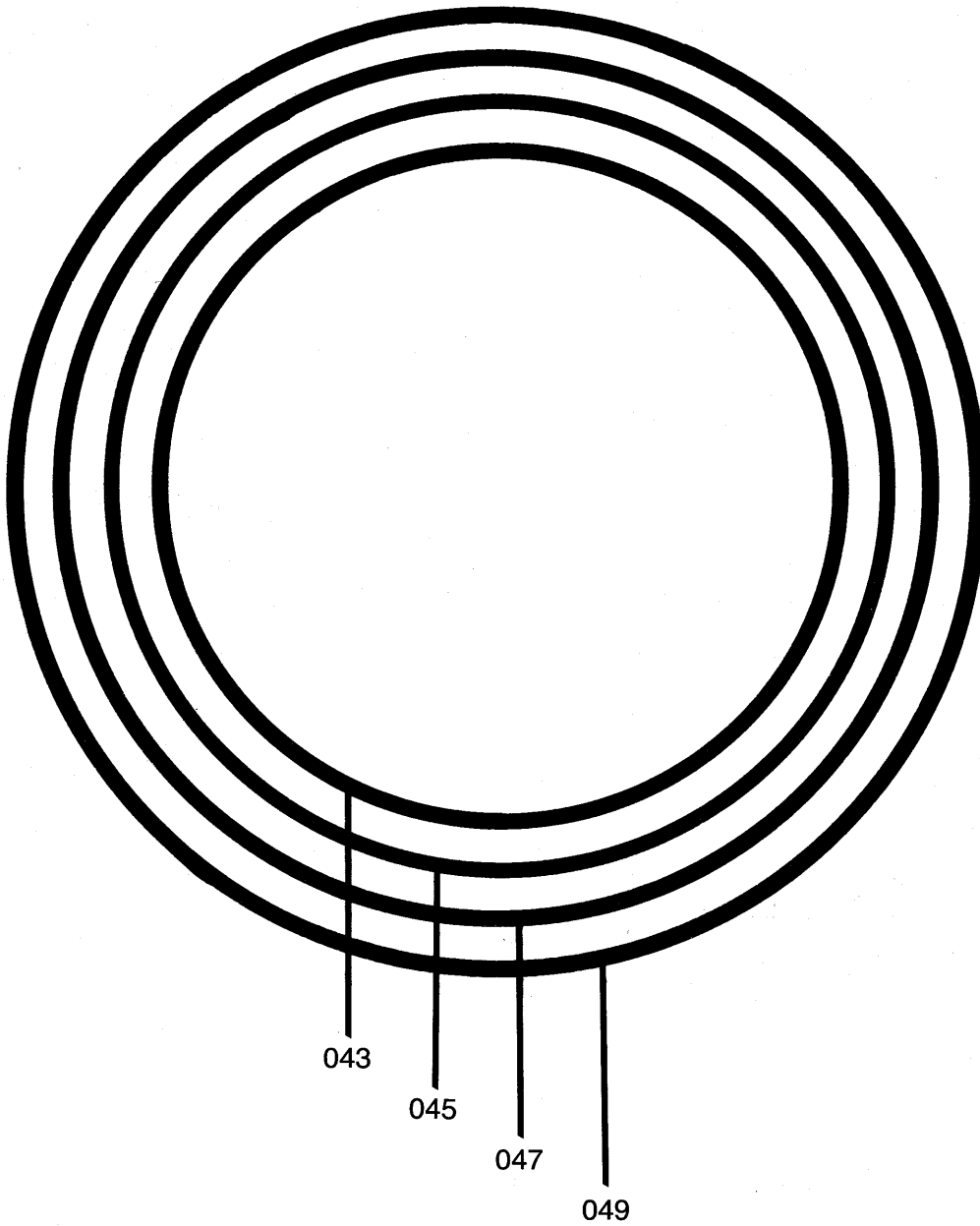

000 SERIES -- .070 cross section

**000 SERIES    044    046    048    050**

000 SERIES IS SPACED IN TWO NUMBER INCREMENTS

000 SERIES – .070 cross section

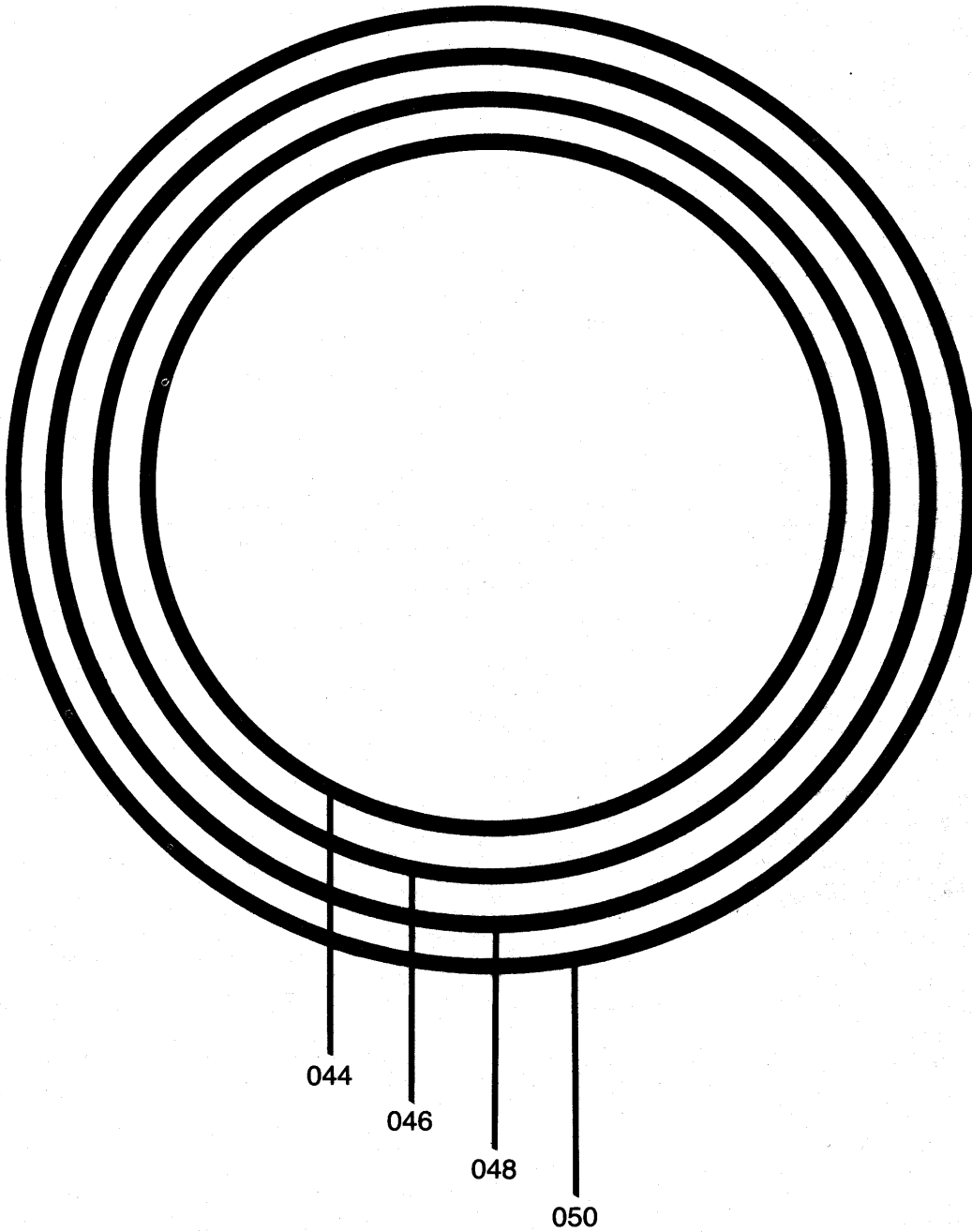



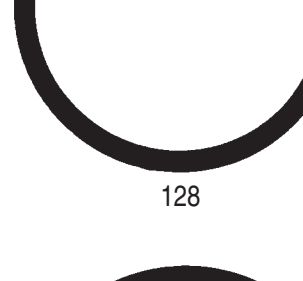
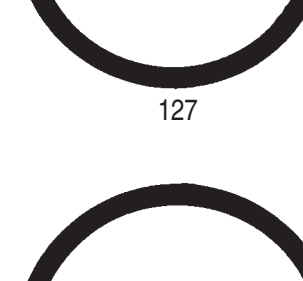
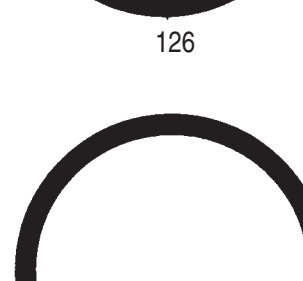
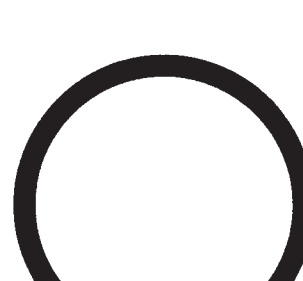
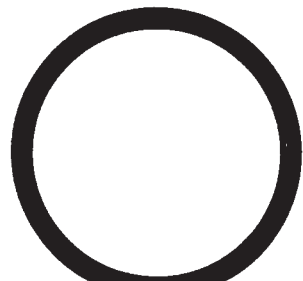
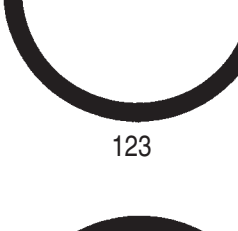
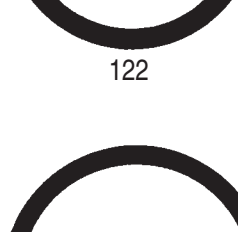
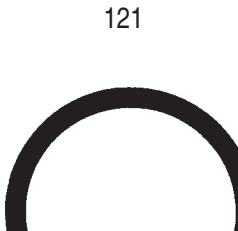
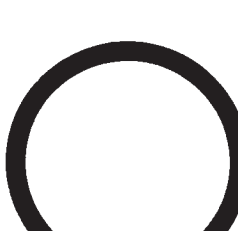
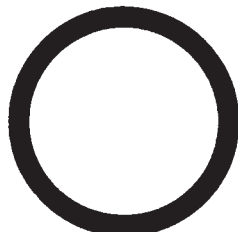
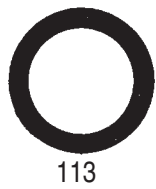

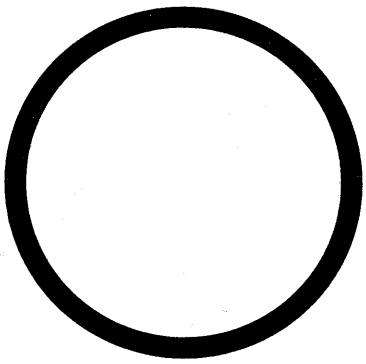

130

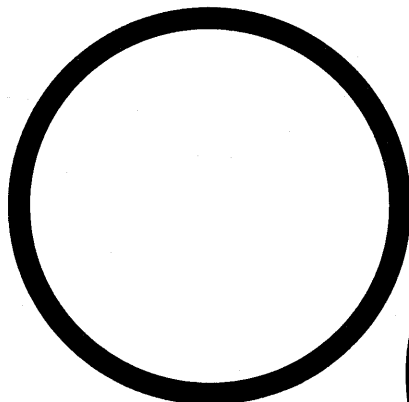

134

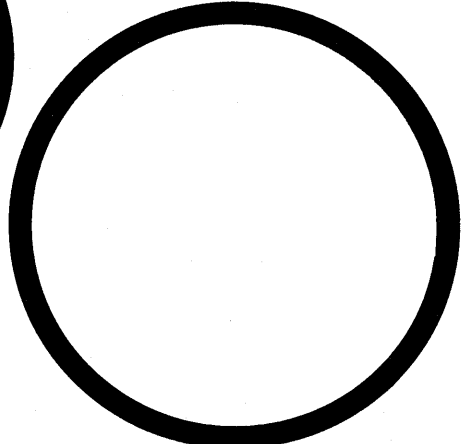

138

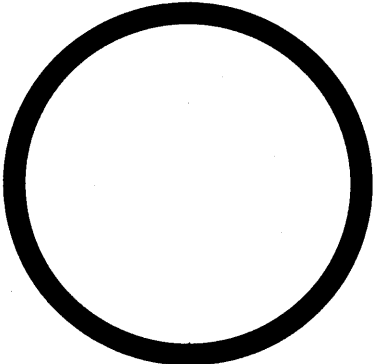

131

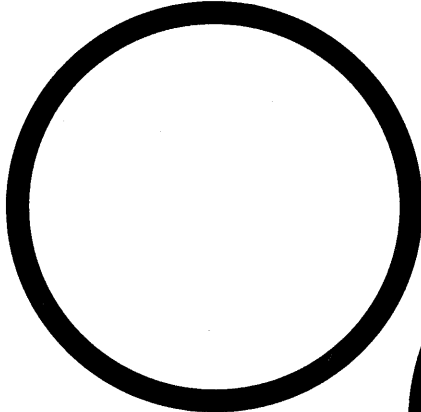

135

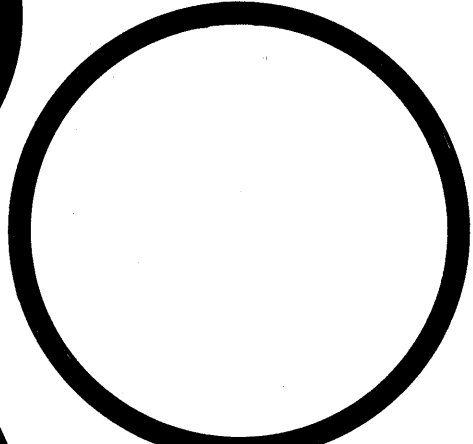

139

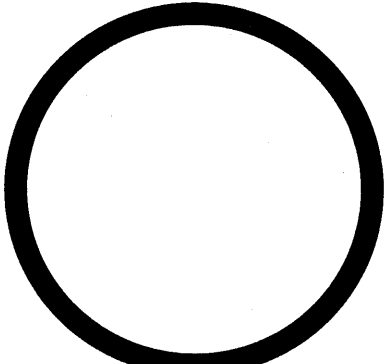

132

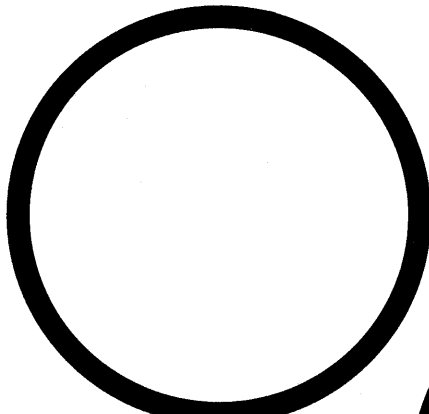

136

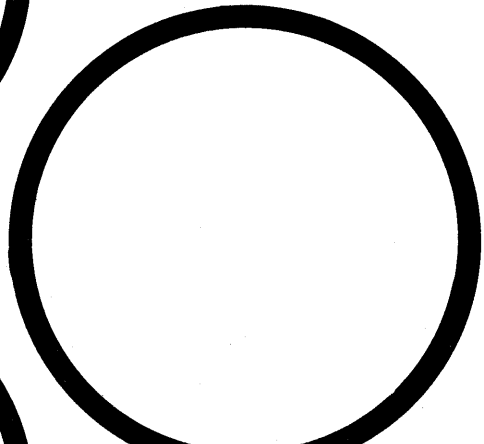

140

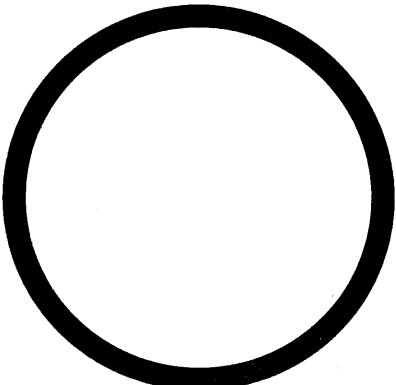

133

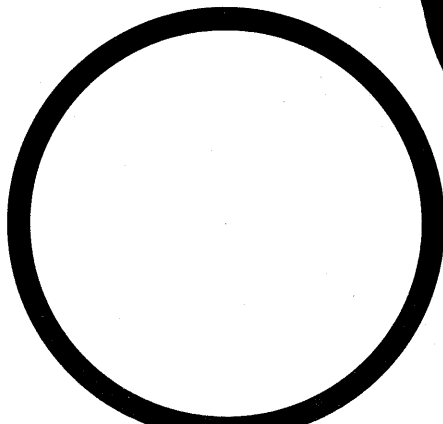

137

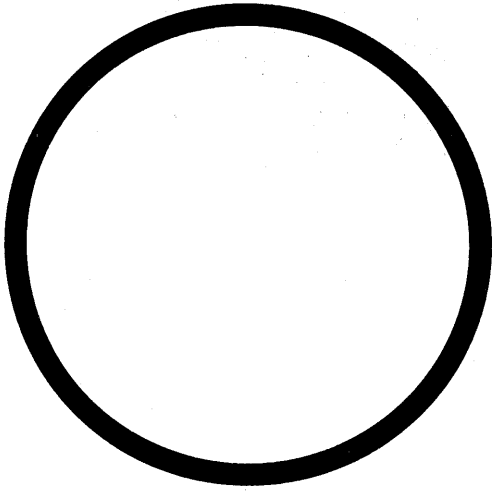

141

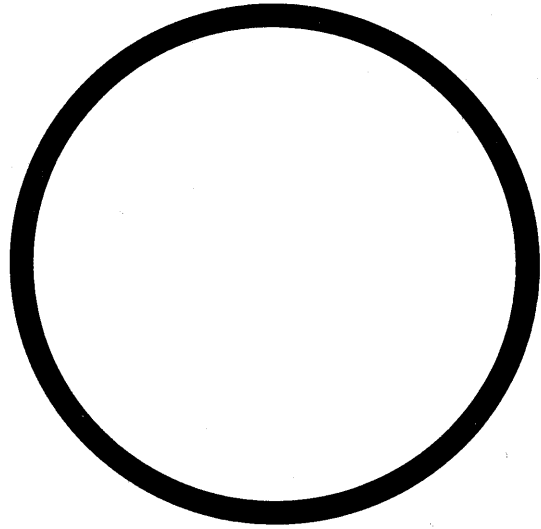

144

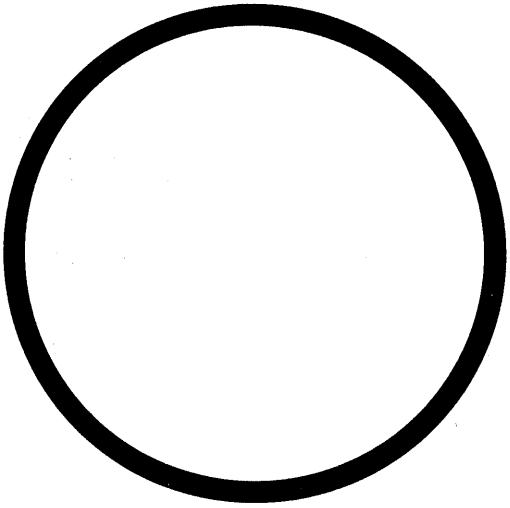

142

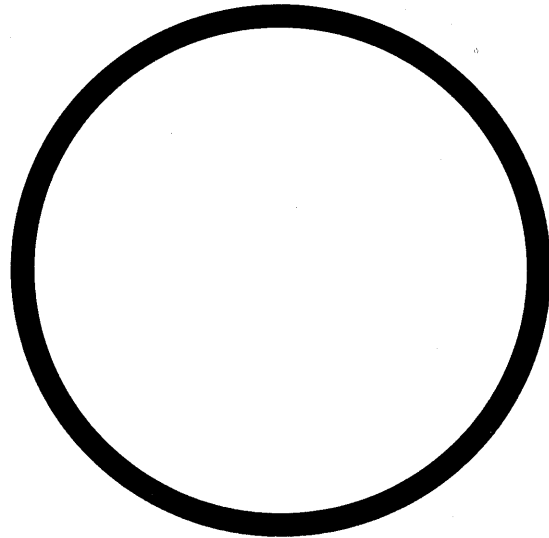

145

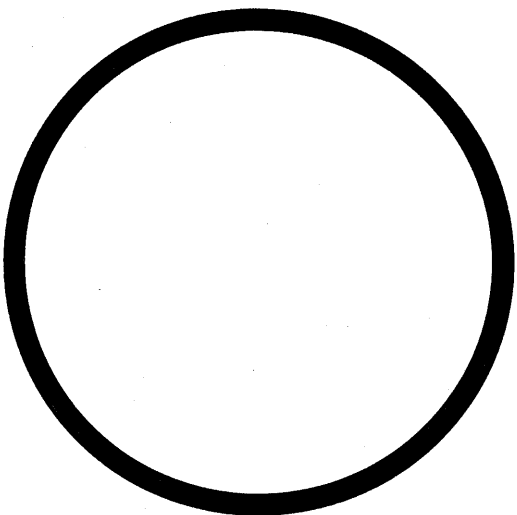

143

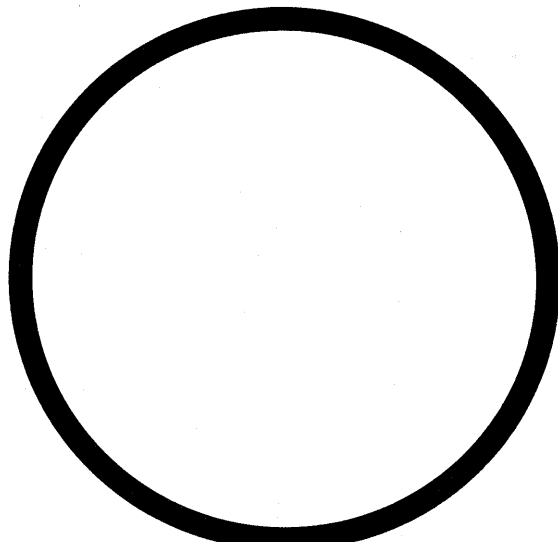

146

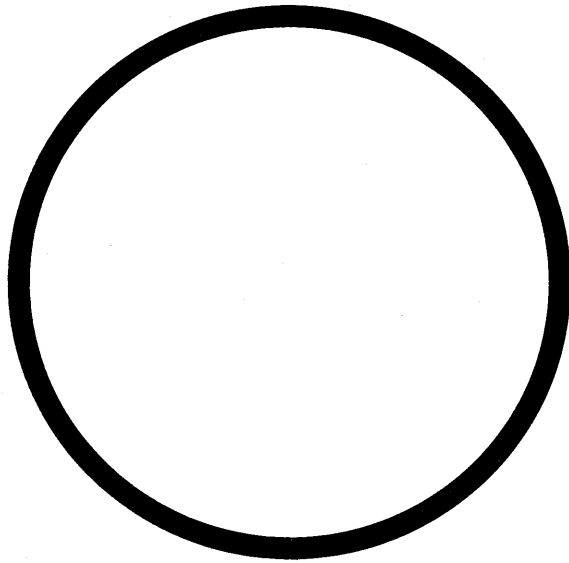

147

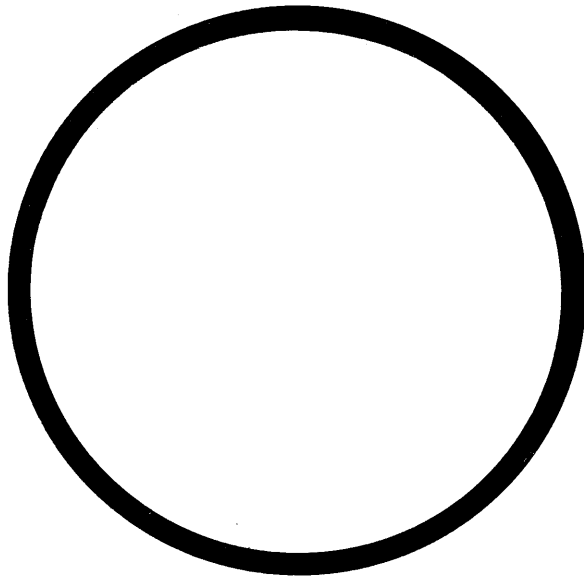

148

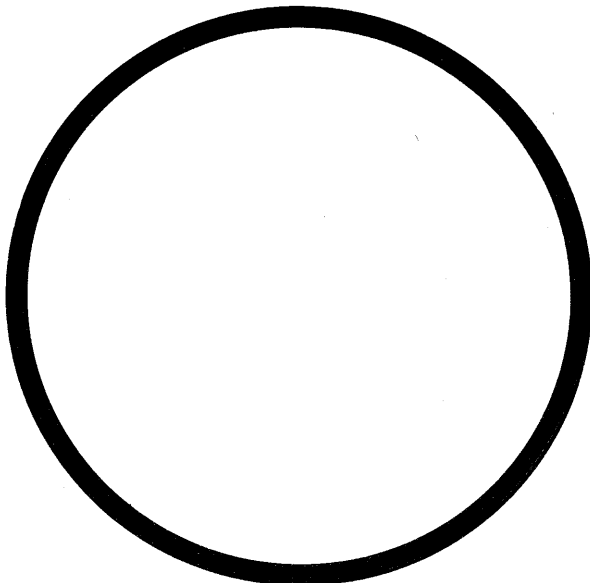

149

**100 SERIES**

**150**

**154**

**158**

**162**

**166**

100 SERIES IS SPACED IN FOUR NUMBER INCREMENTS

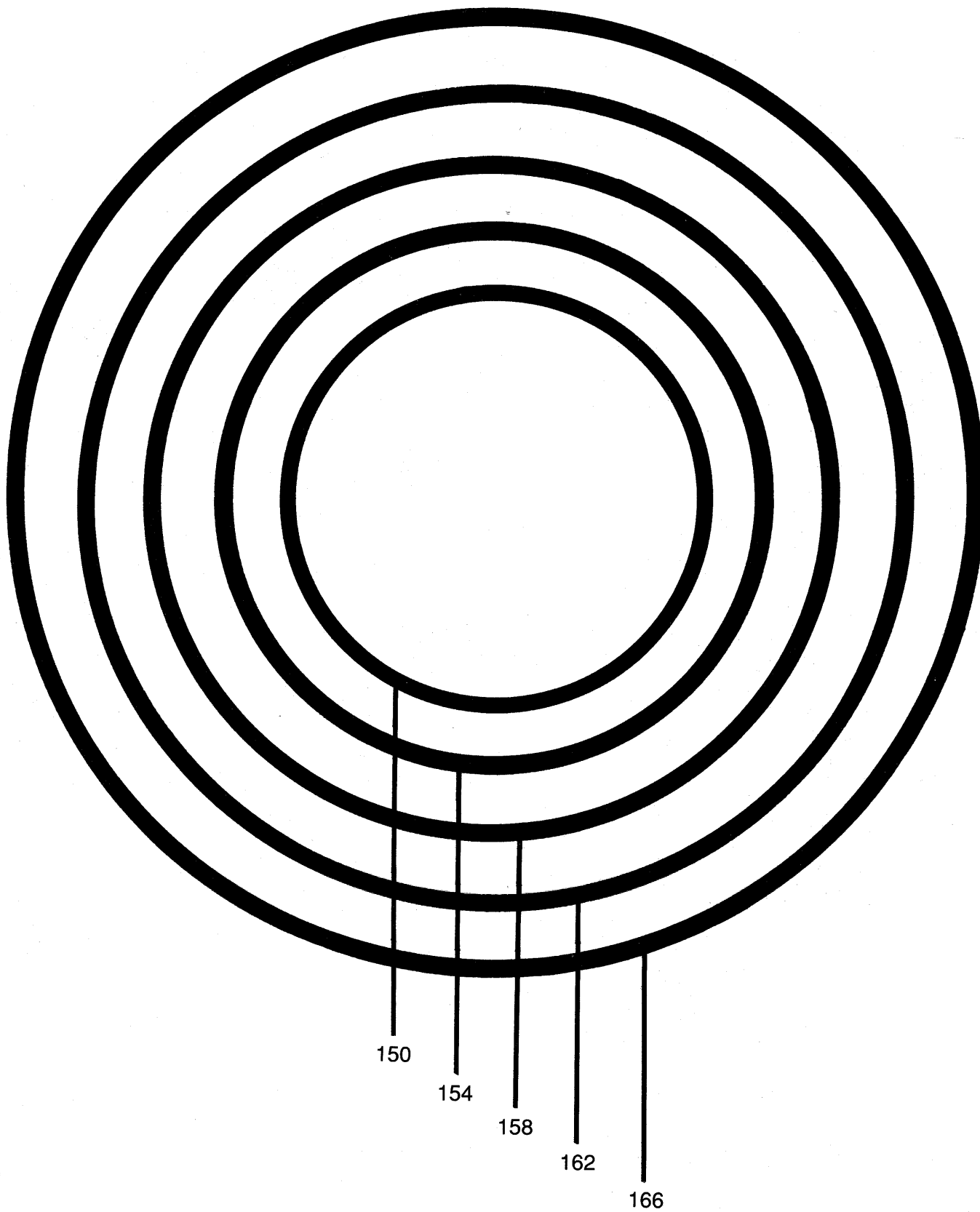

100 SERIES – .103 cross section

100 SERIES

151

155

159

163

167

100 SERIES IS SPACED IN FOUR NUMBER INCREMENTS

100 SERIES - .103 cross section

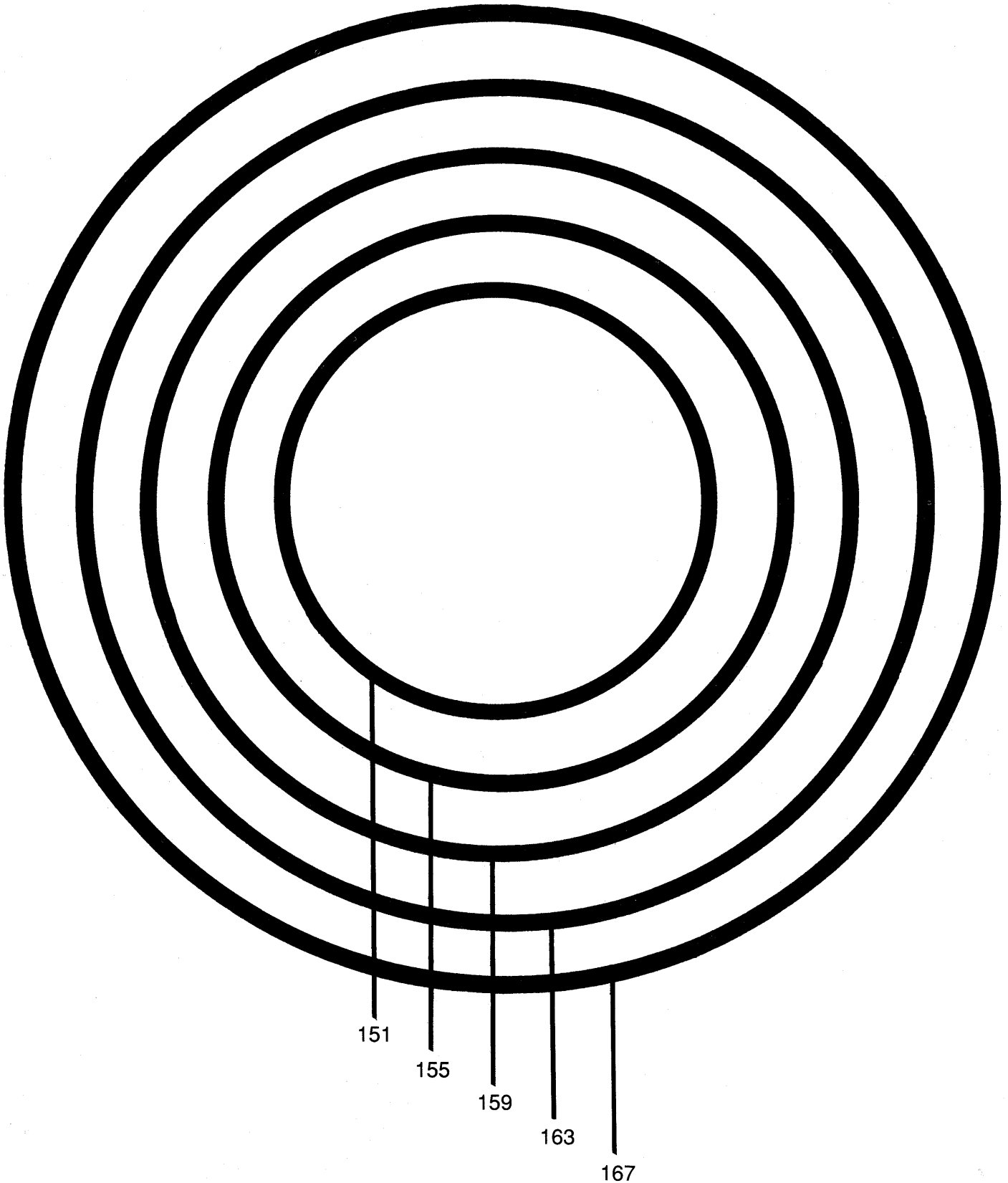

**100 SERIES**

**152**

**156**

**160**

**164**

100 SERIES IS SPACED IN FOUR NUMBER INCREMENTS

100 SERIES – .103 cross section

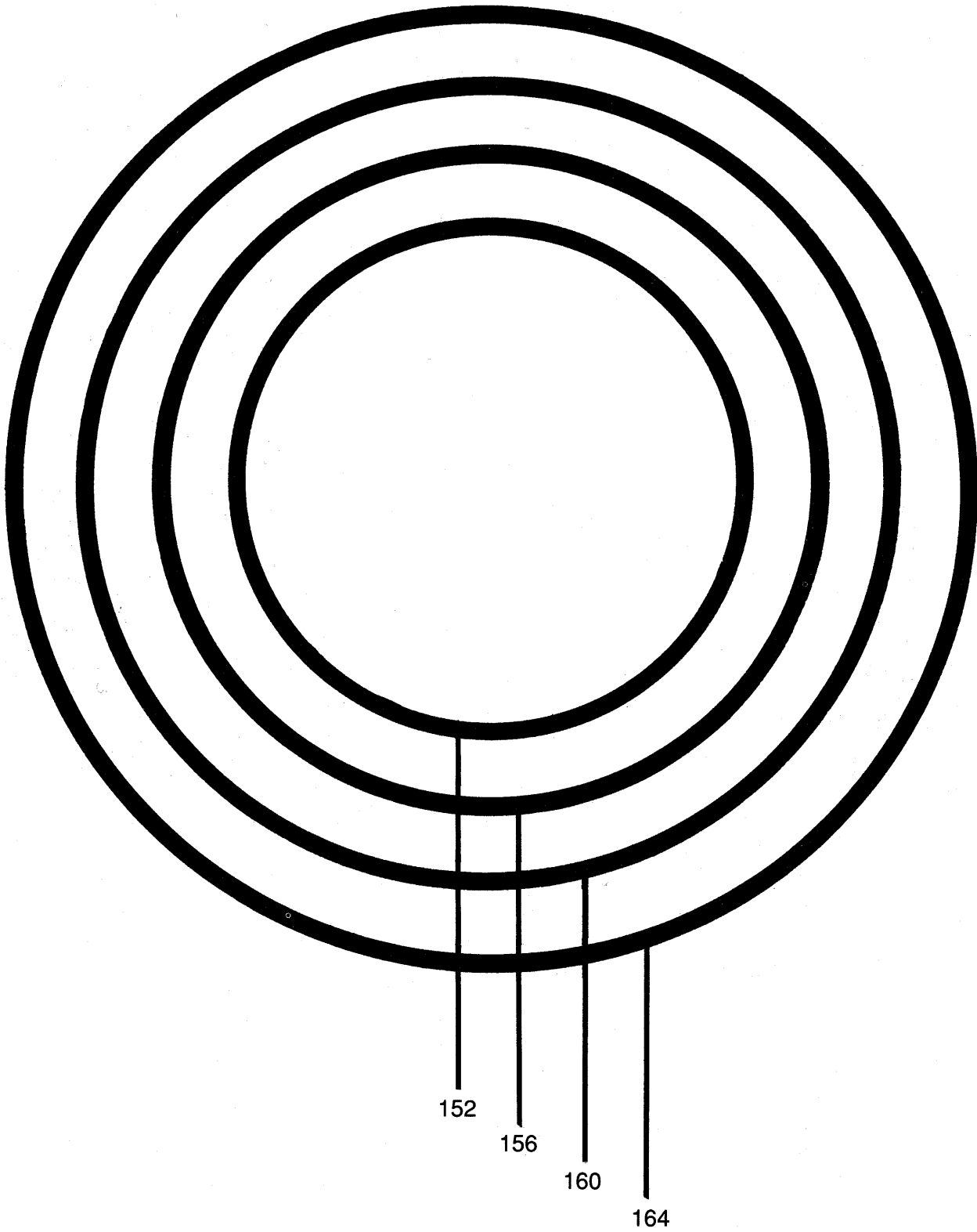

**100 SERIES**

**153**

**157**

**161**

**165**

100 SERIES IS SPACED IN FOUR NUMBER INCREMENTS

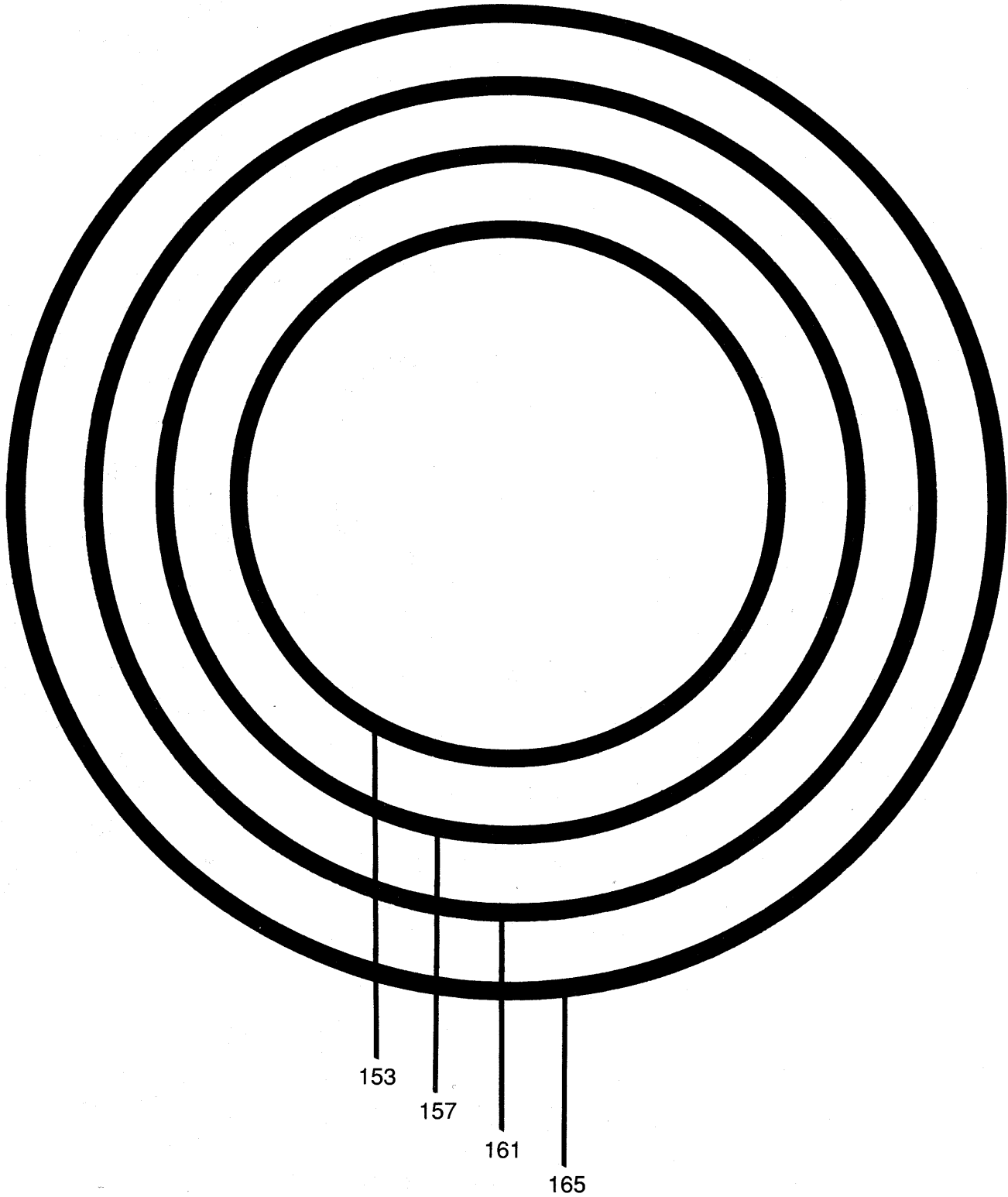

100 SERIES – .103 cross section





201



202



203



204



205



206



207



208



209



210

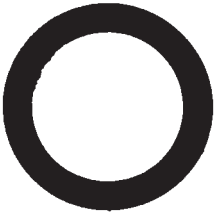

211



212

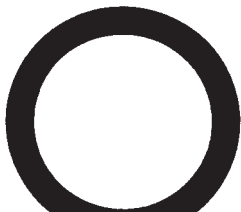

213

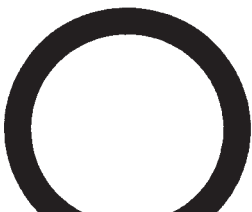

214



215

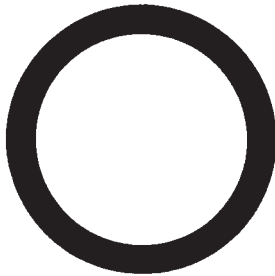

216

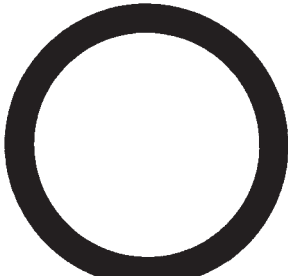

217

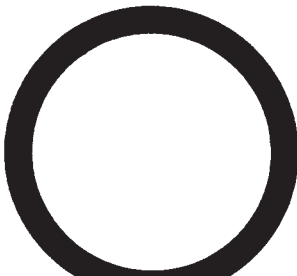

218

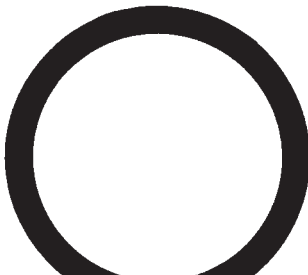

219

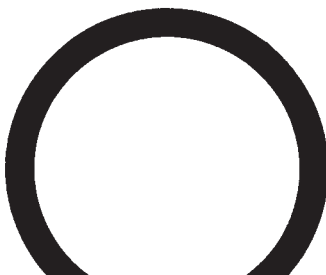

220

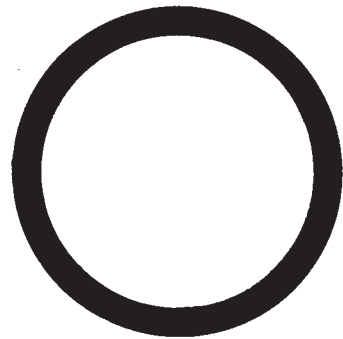

221

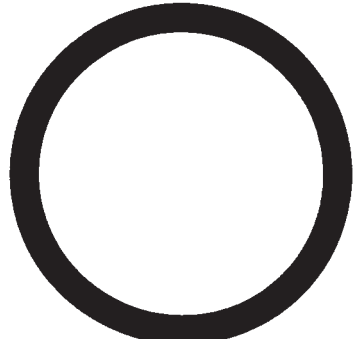

222

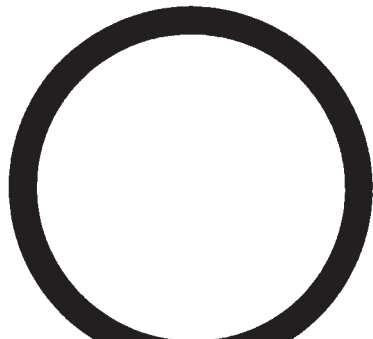

223

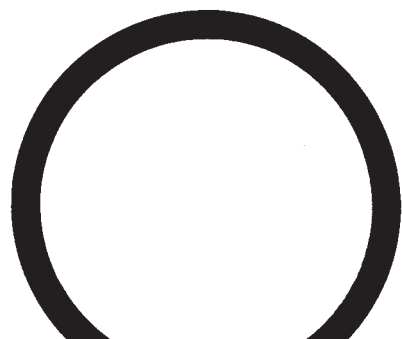

224

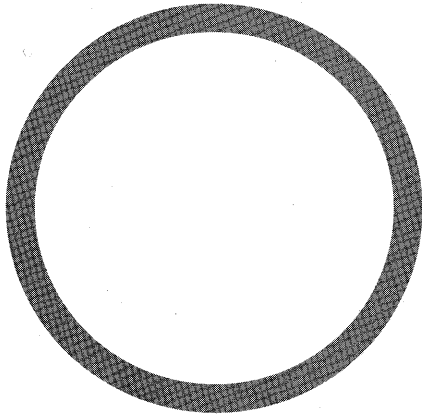

225

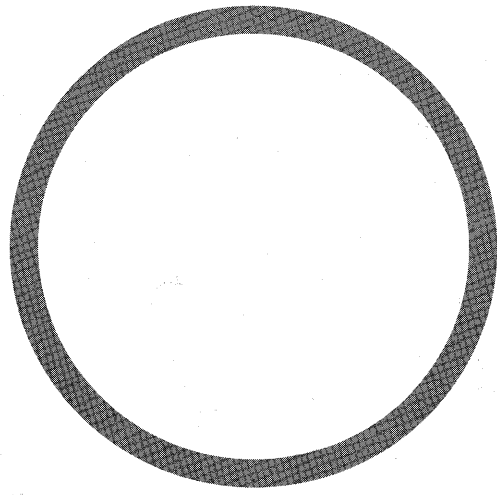

228

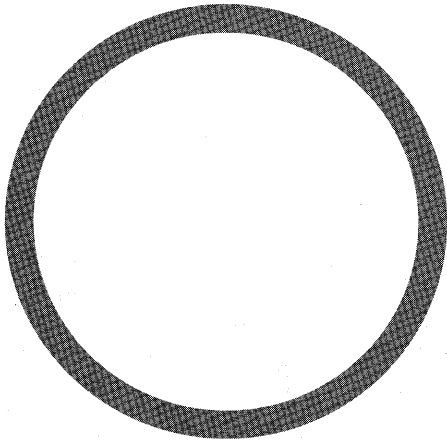

226

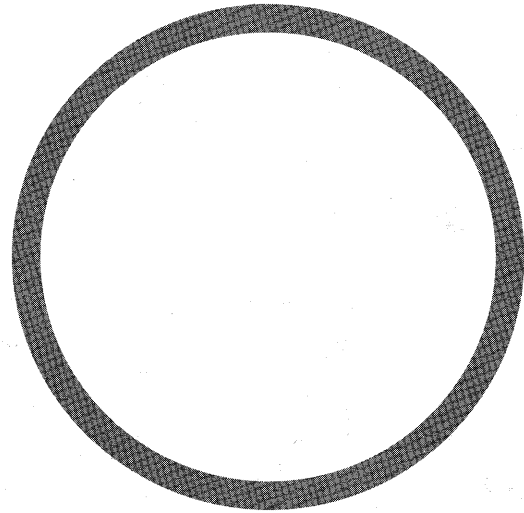

229

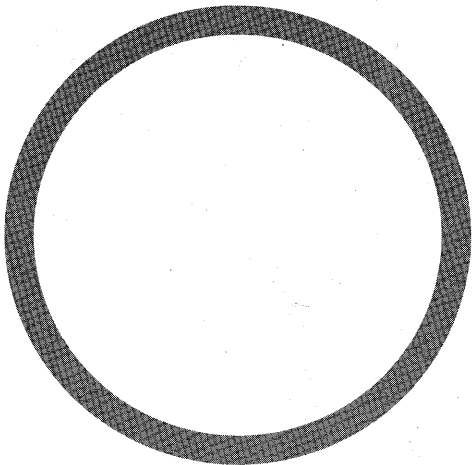

227

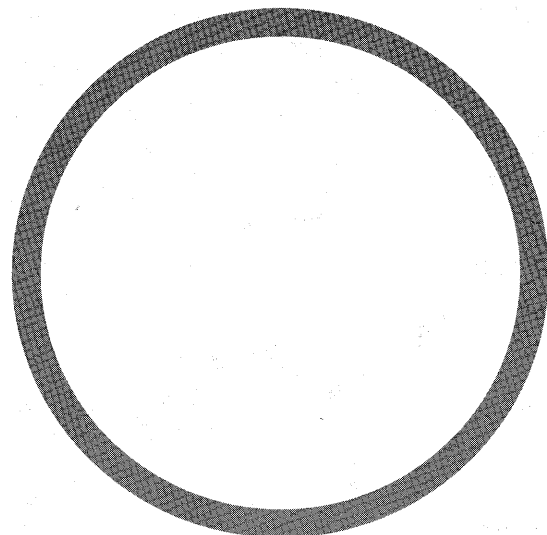

230

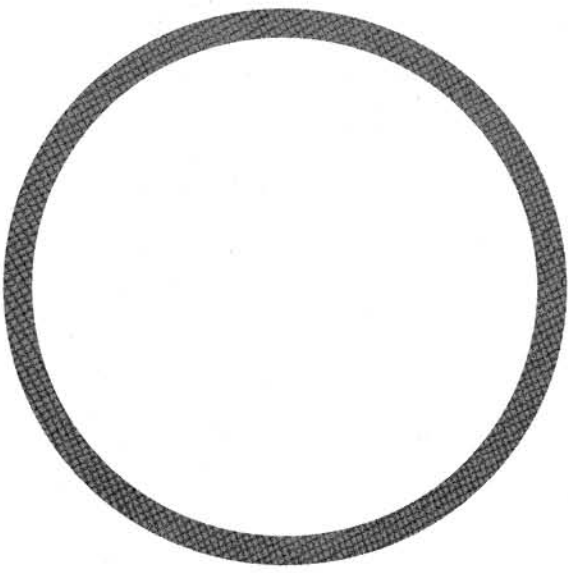

231

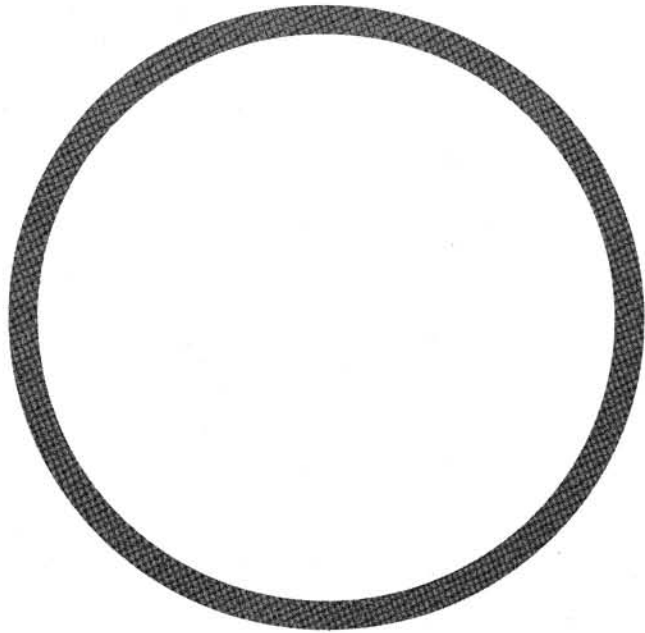

234

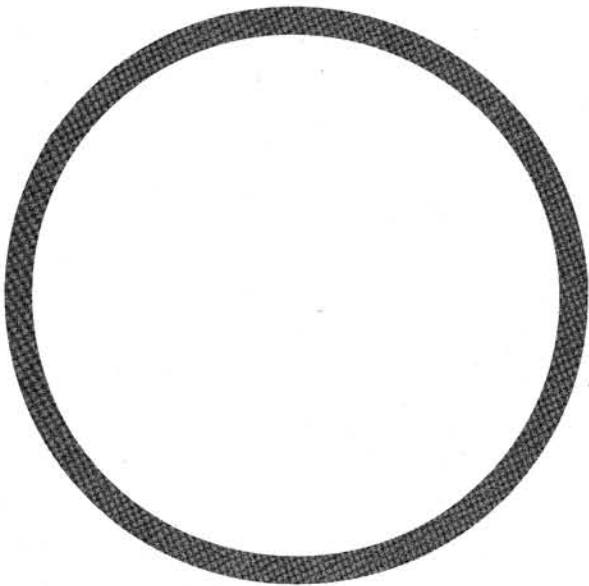

232

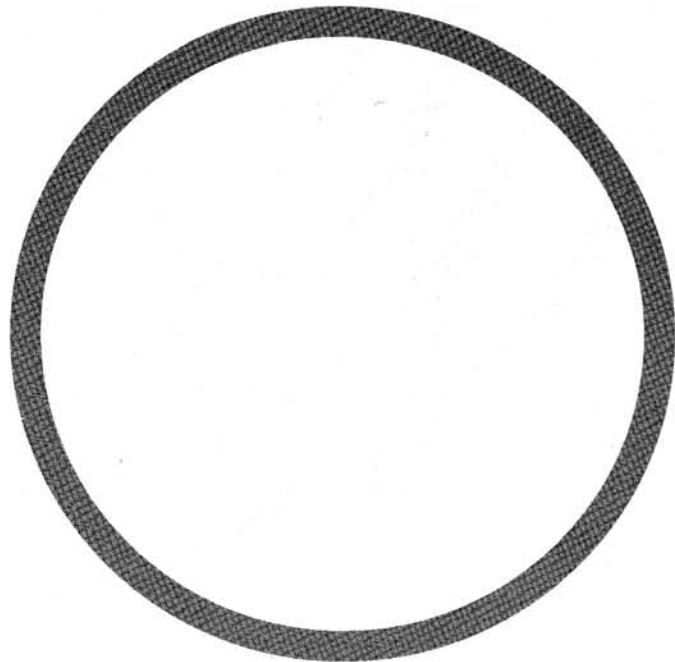

235

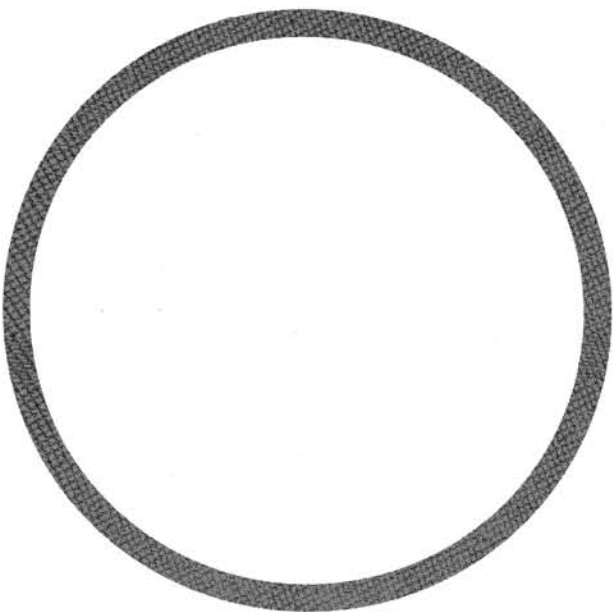

233

200 SERIES

236

244

252

260

200 SERIES IS SPACED IN EIGHT NUMBER INCREMENTS

200 SERIES – .139 cross section

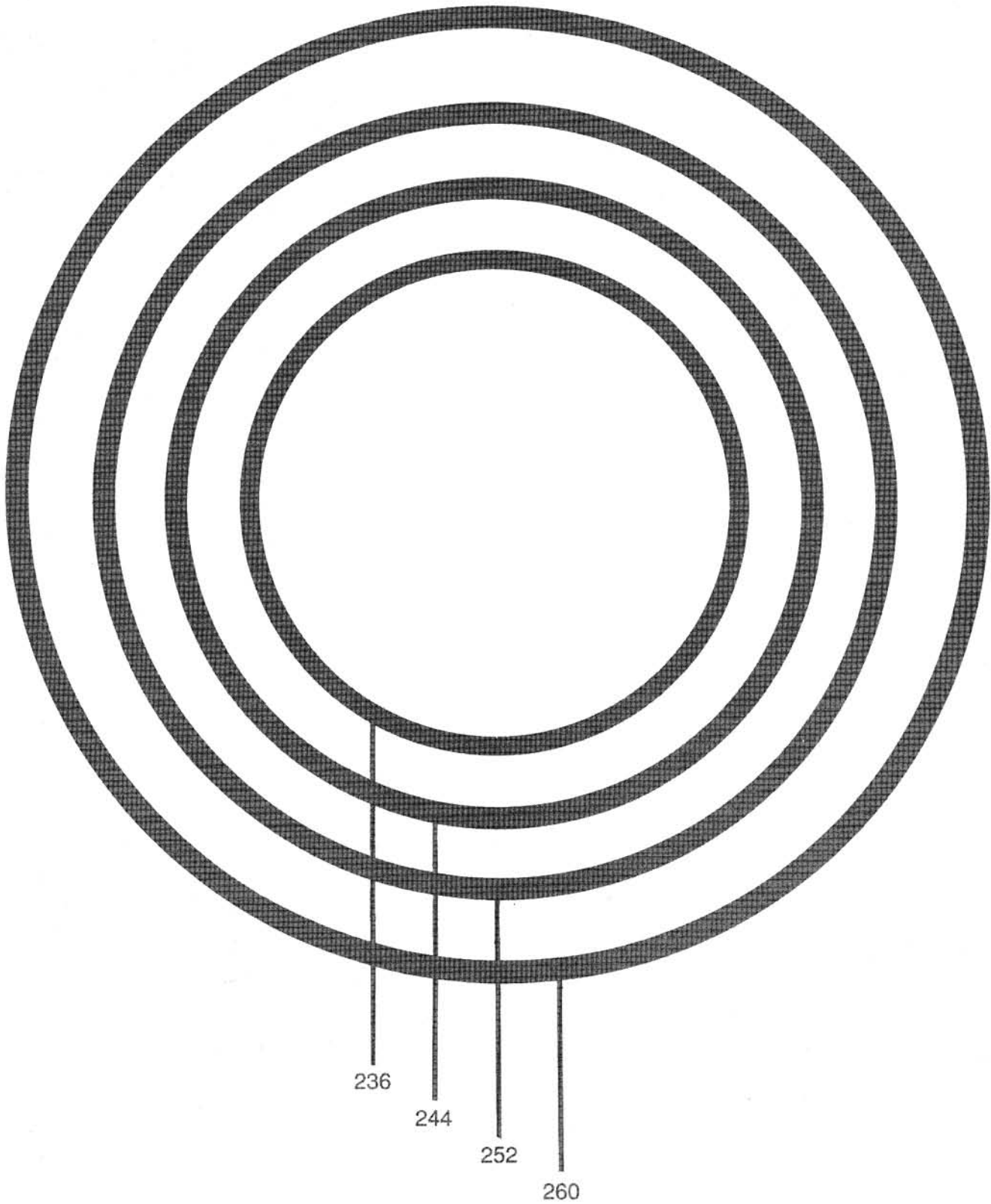

200 SERIES

237

245

253

261

200 SERIES IS SPACED IN EIGHT NUMBER INCREMENTS

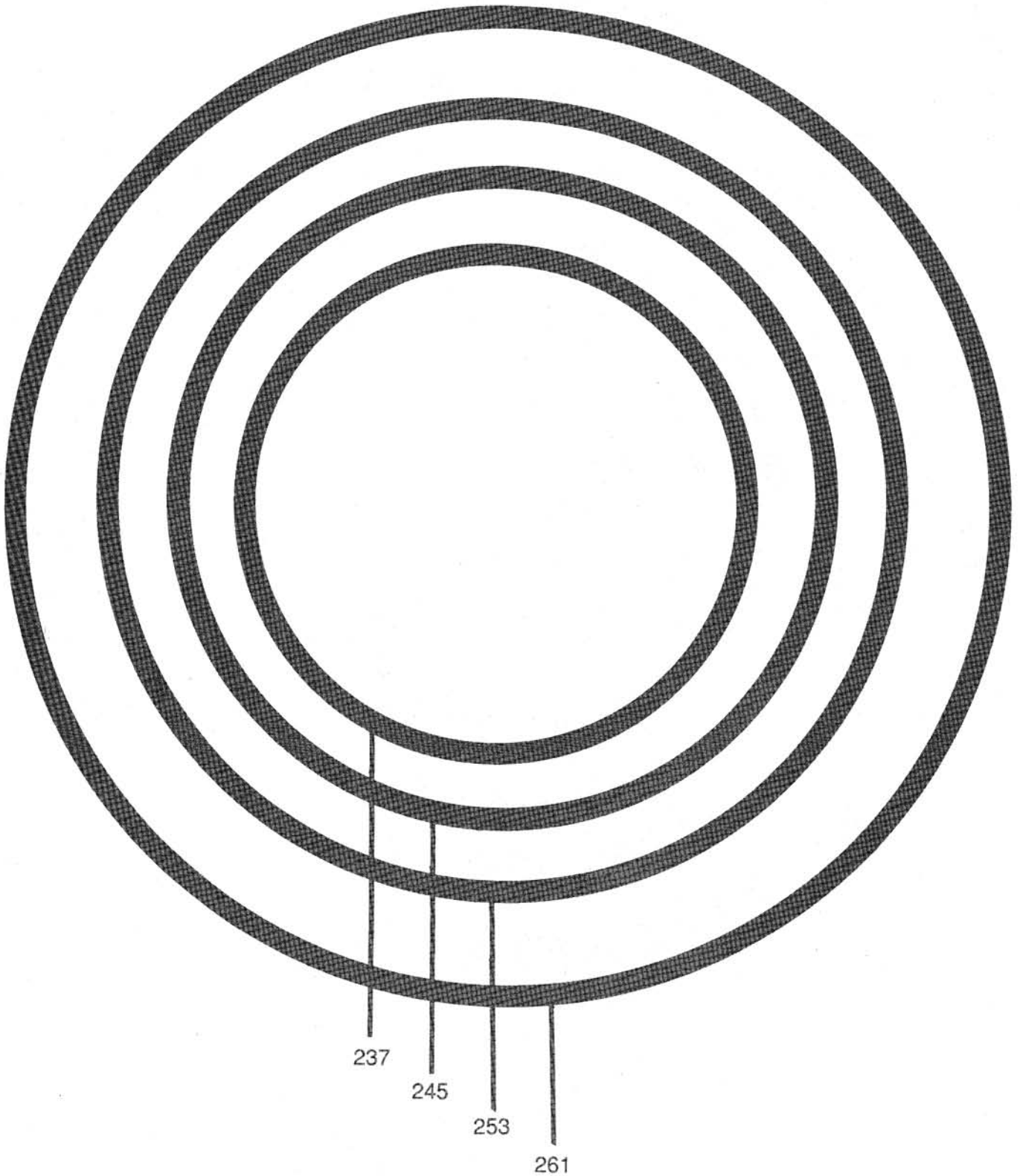

200 SERIES – .139 cross section

200 SERIES

238

246

254

262

200 SERIES IS SPACED IN EIGHT NUMBER INCREMENTS

200 SERIES – .139 cross section

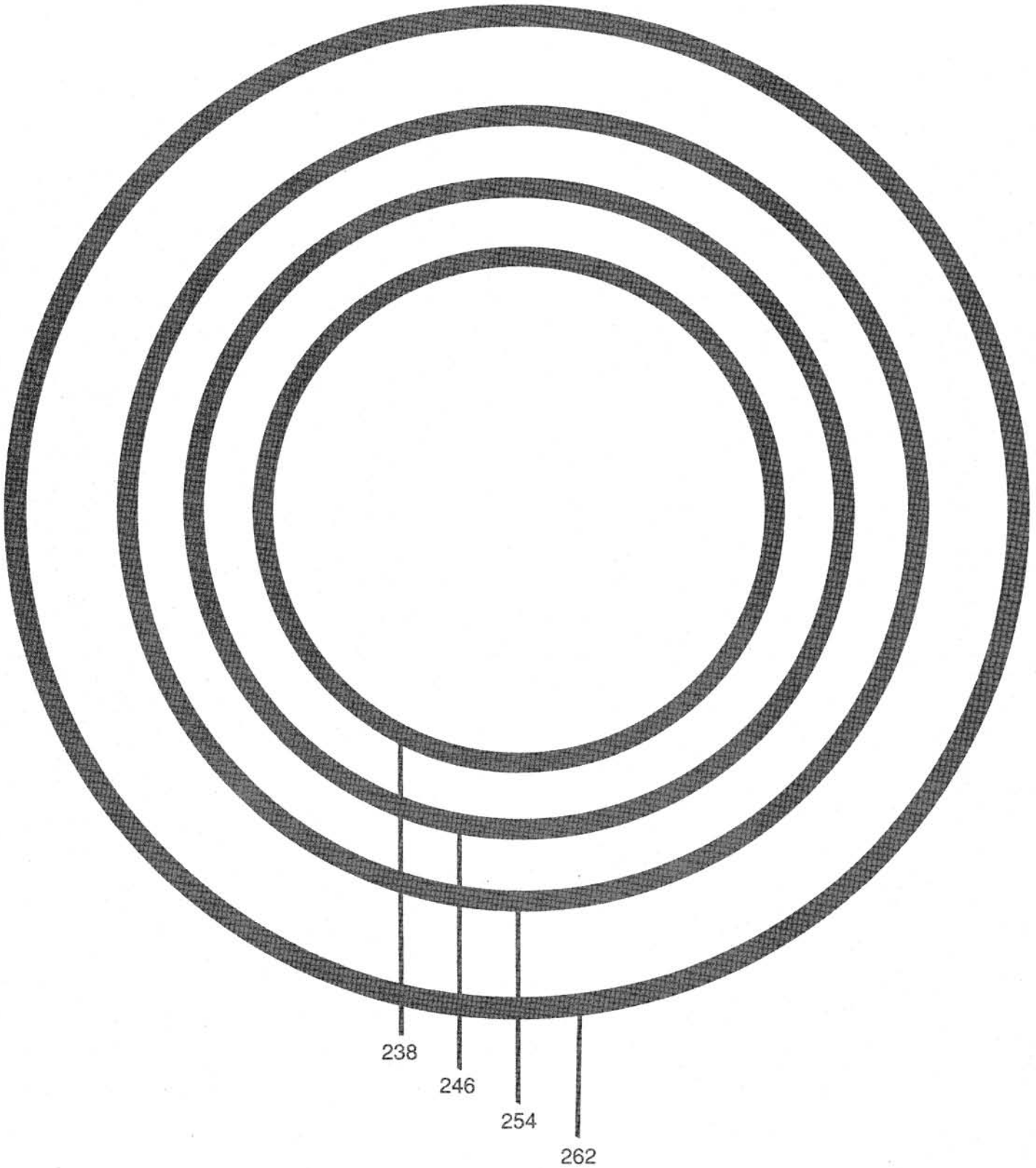

**200 SERIES**

**238**

**246**

**254**

**262**

200 SERIES IS SPACED IN EIGHT NUMBER INCREMENTS

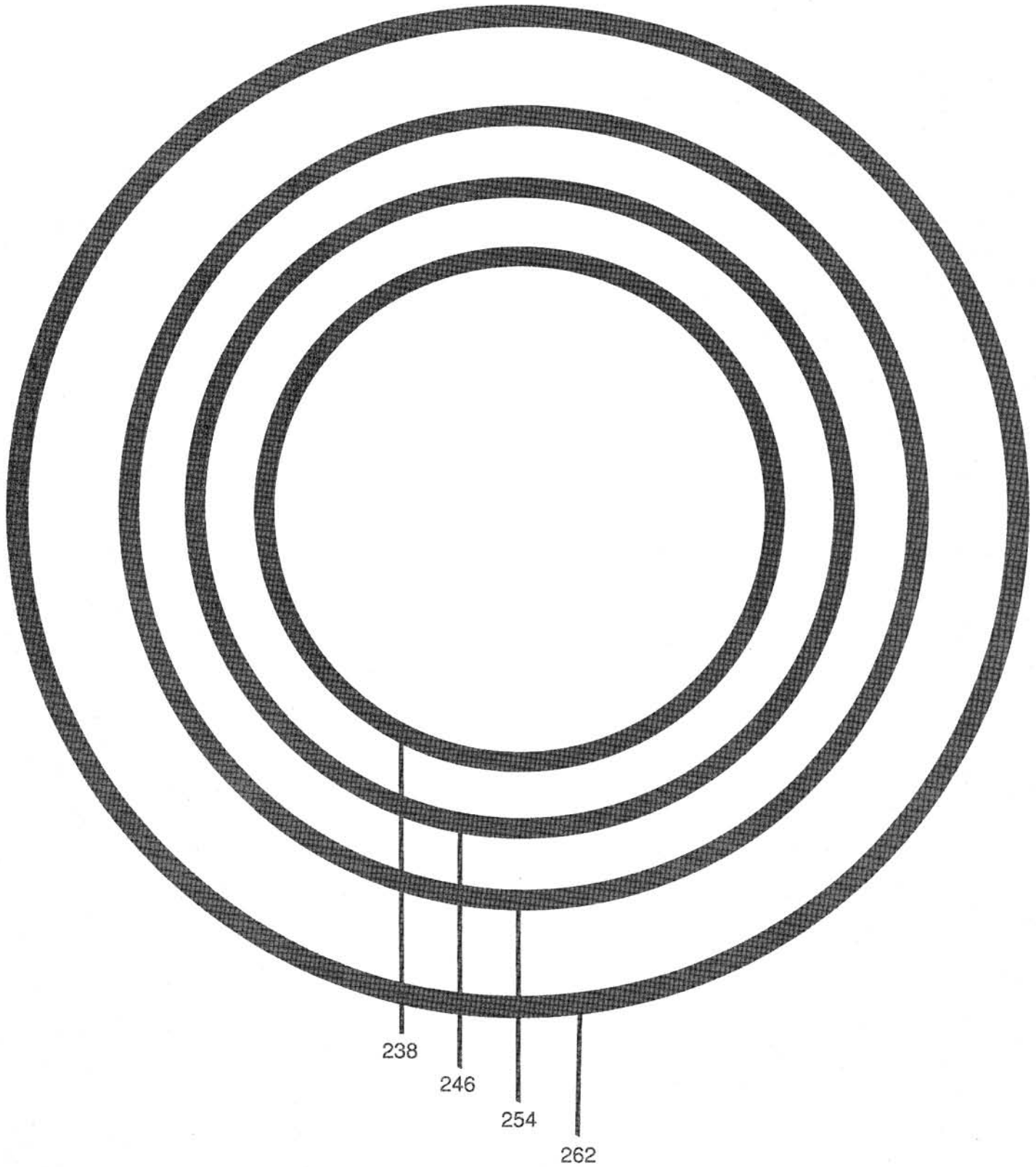

200 SERIES – .139 cross section

200 SERIES 239 247 255

200 SERIES IS SPACED IN EIGHT NUMBER INCREMENTS

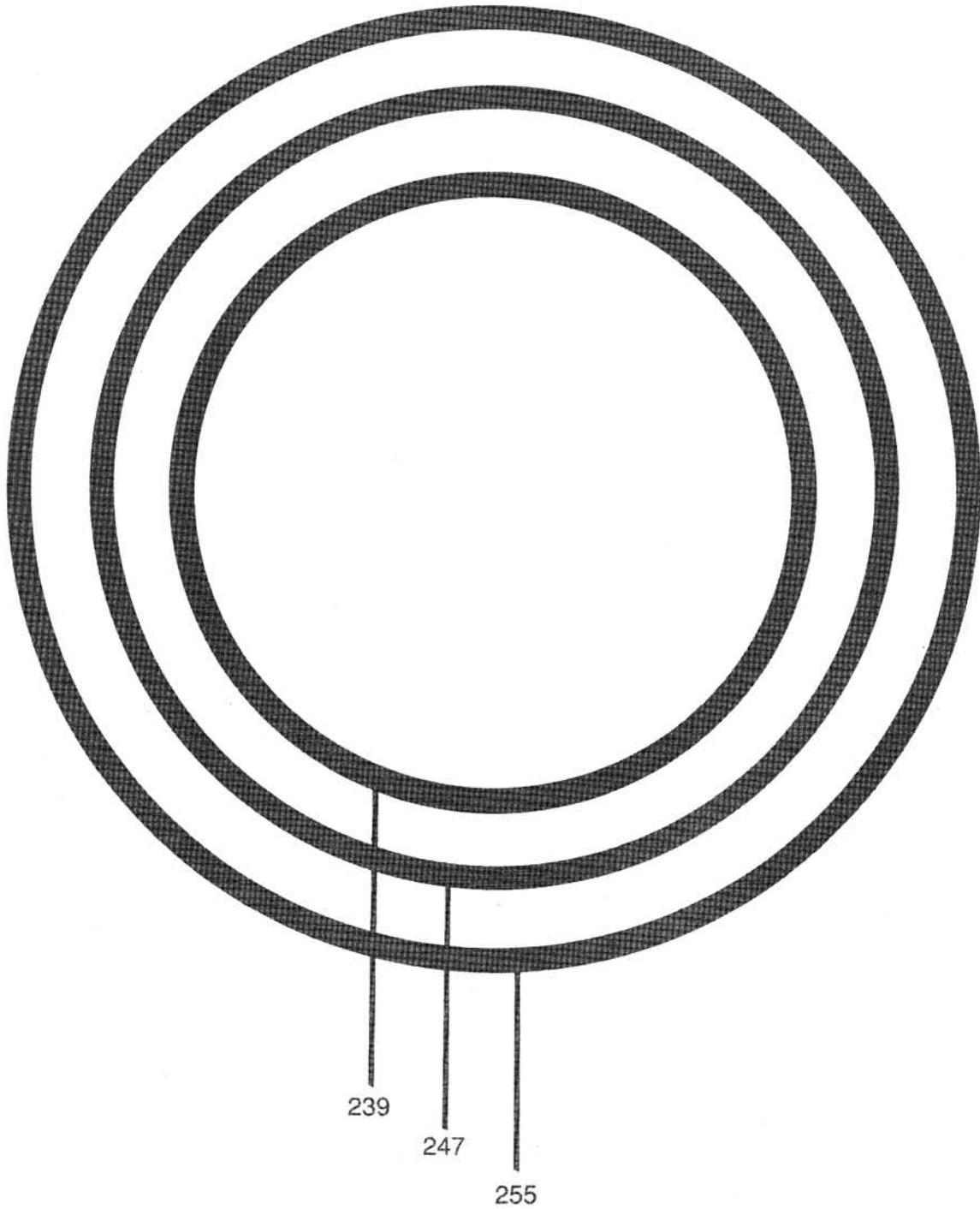

200 SERIES – .139 cross section



200 SERIES

240

248

256

200 SERIES IS SPACED IN EIGHT NUMBER INCREMENTS

200 SERIES – .139 cross section

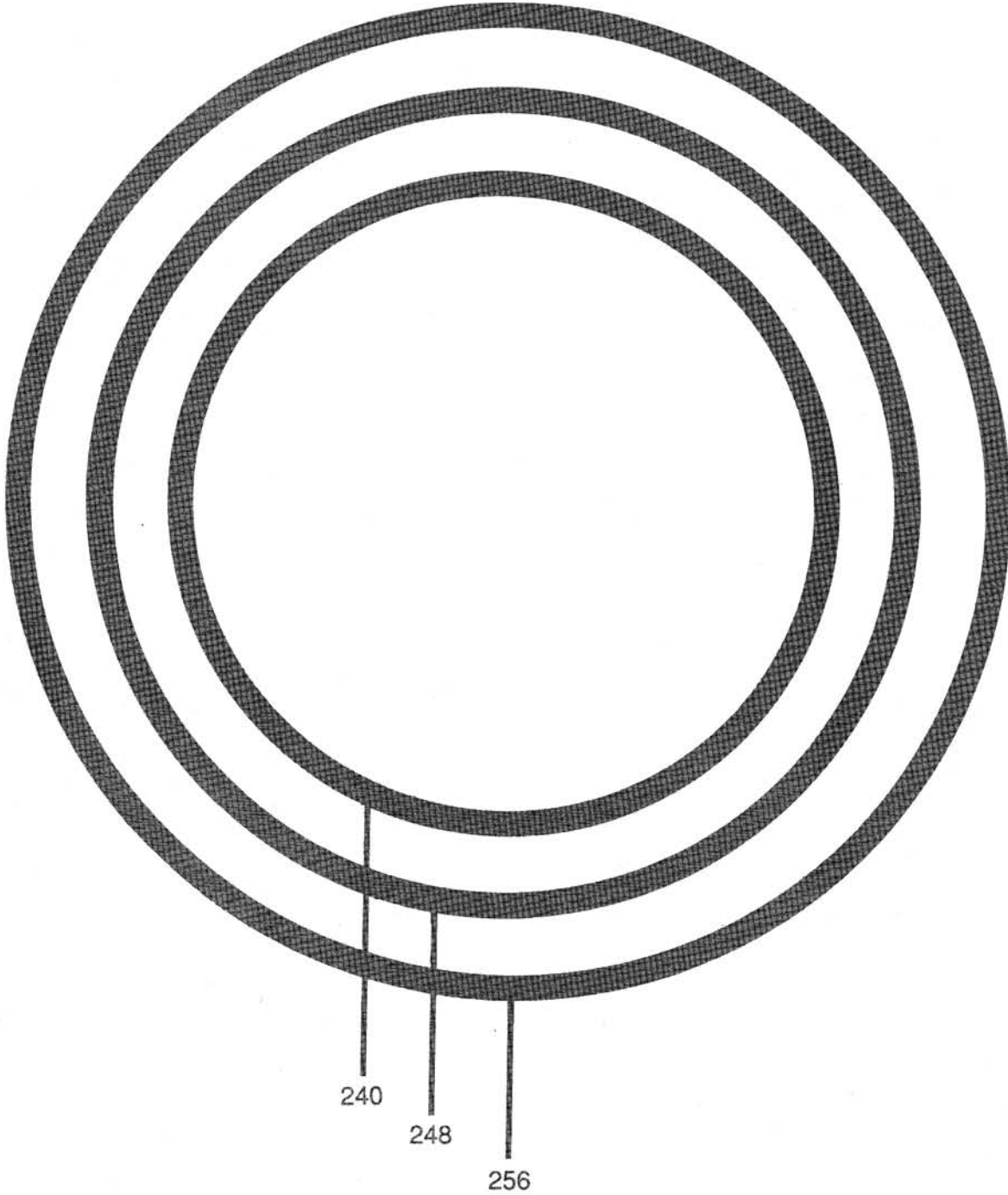

200 SERIES

241

249

257

200 SERIES IS SPACED IN EIGHT NUMBER INCREMENTS

200 SERIES – .139 cross section

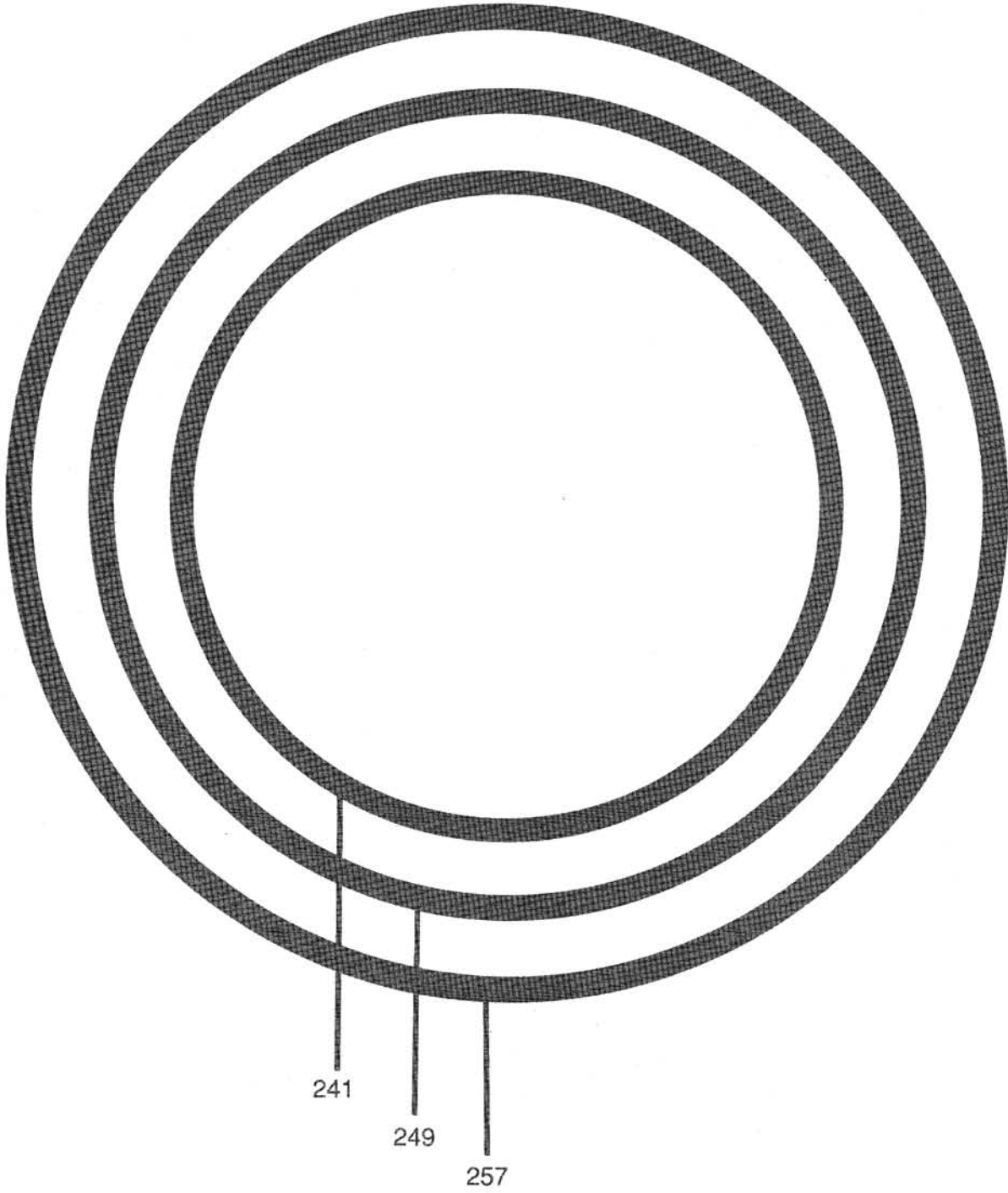

200 SERIES

242

250

258

200 SERIES IS SPACED IN EIGHT NUMBER INCREMENTS

200 SERIES – .139 cross section

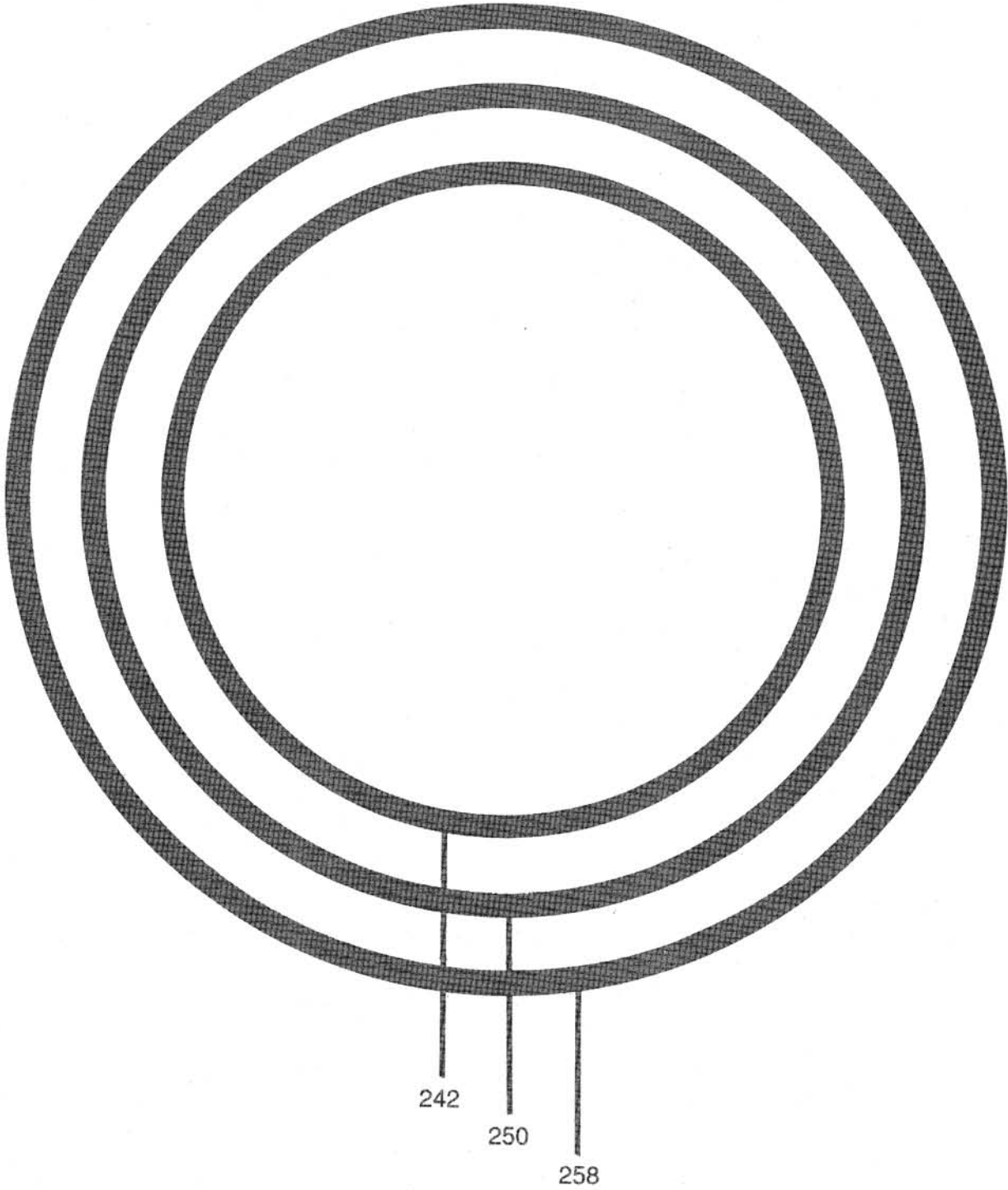

200 SERIES

243

251

259

200 SERIES IS SPACED IN EIGHT NUMBER INCREMENTS

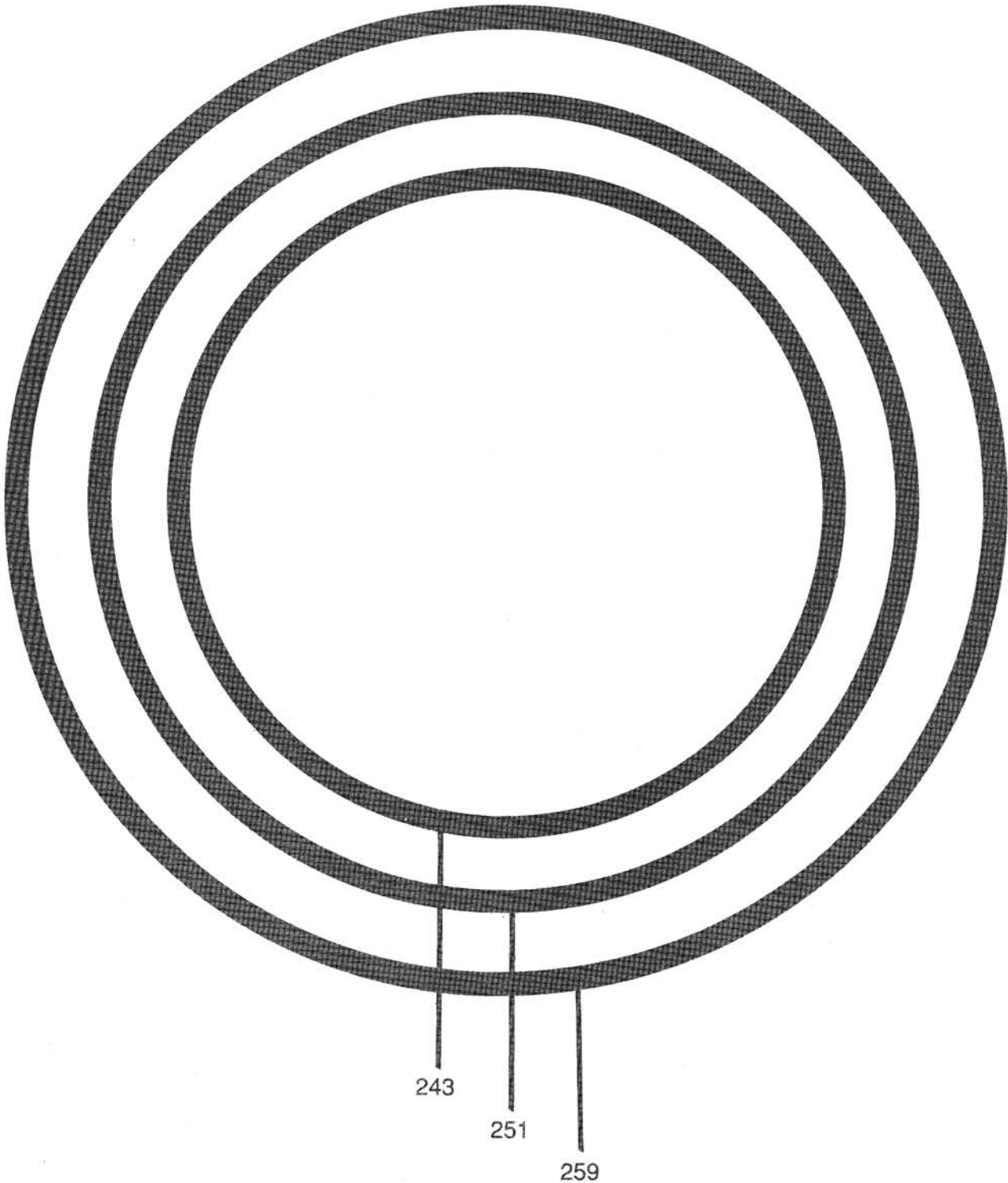

200 SERIES – .139 cross section



309



310



311



312



313



314

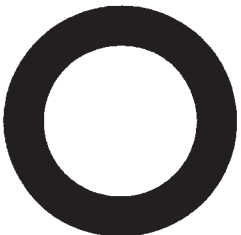

315

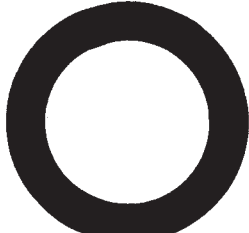

316

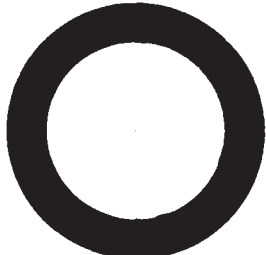

317

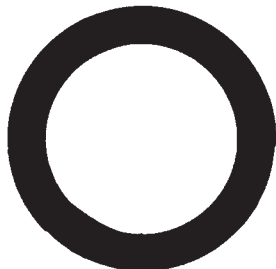

318

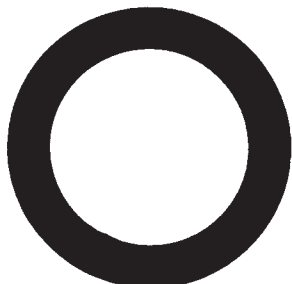

319

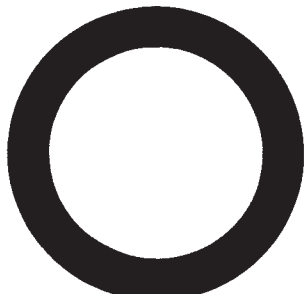

320

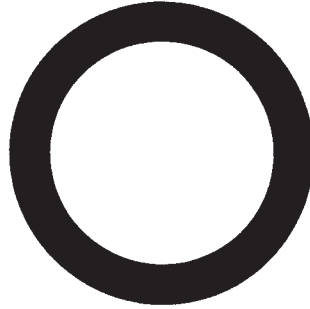

321

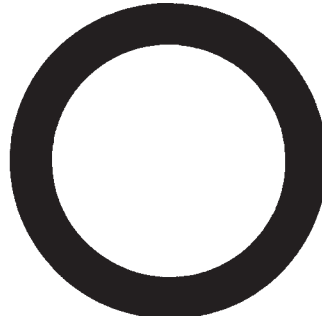

322

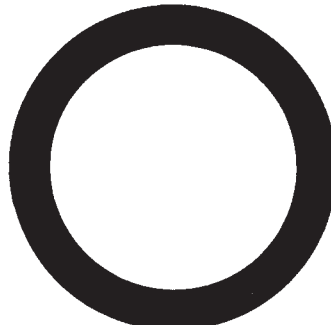

323

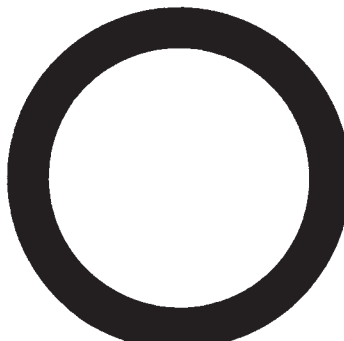

324

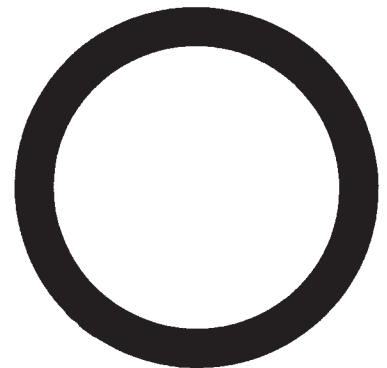

325

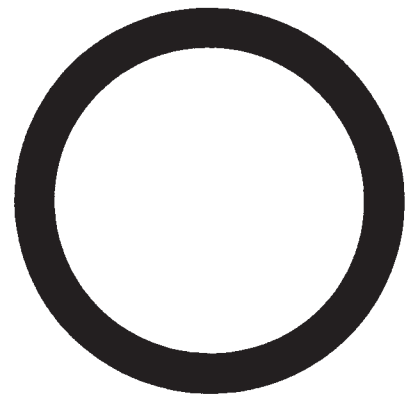

326

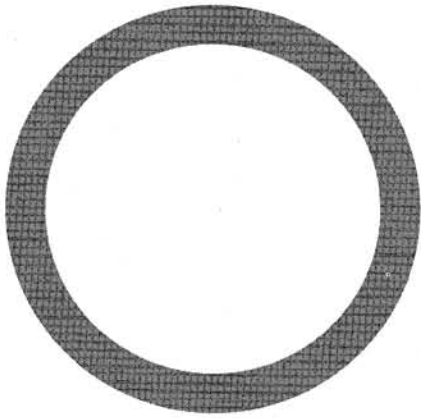

327

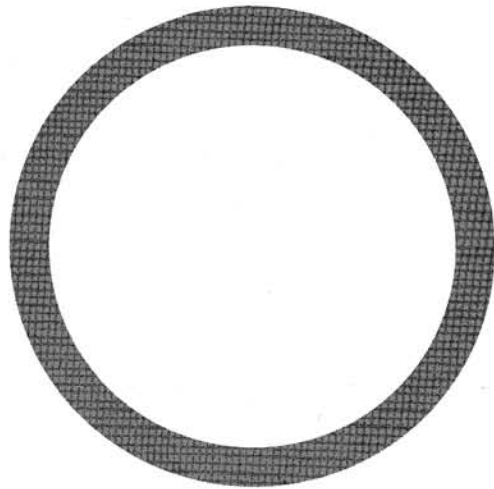

330

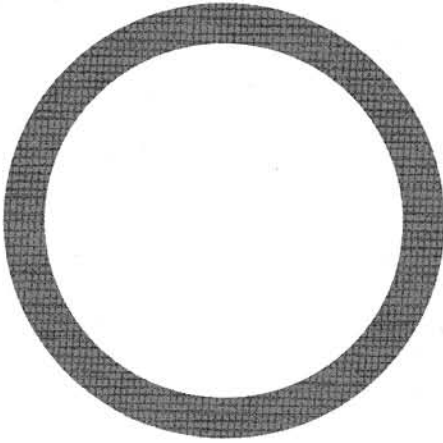

328

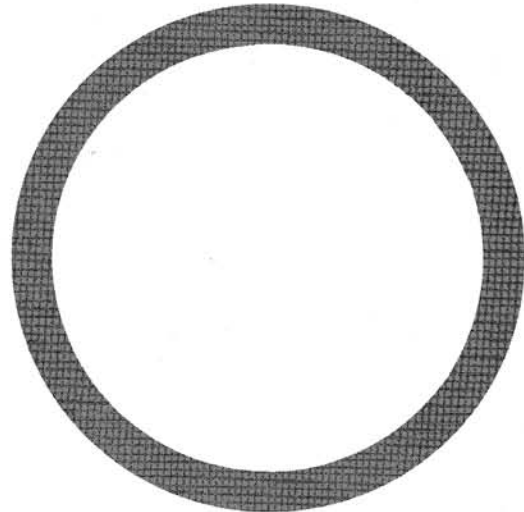

331

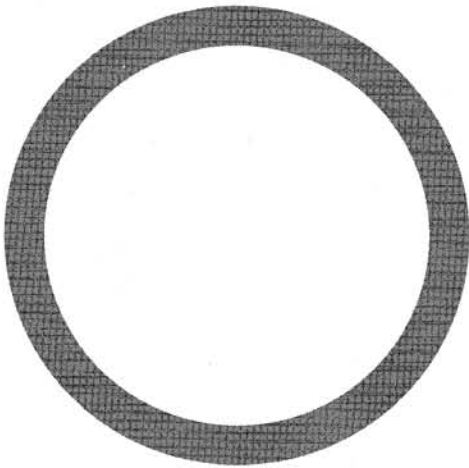

329

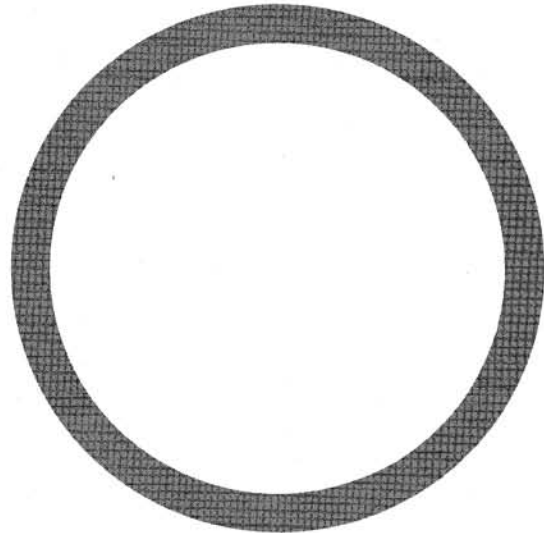

332

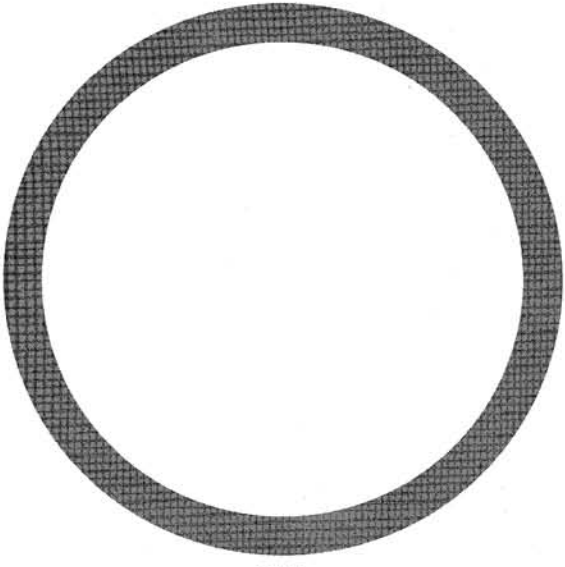

333

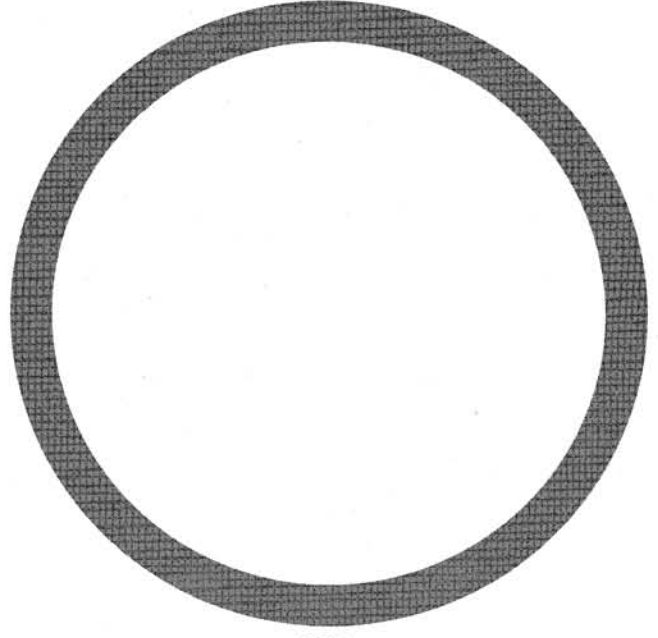

336

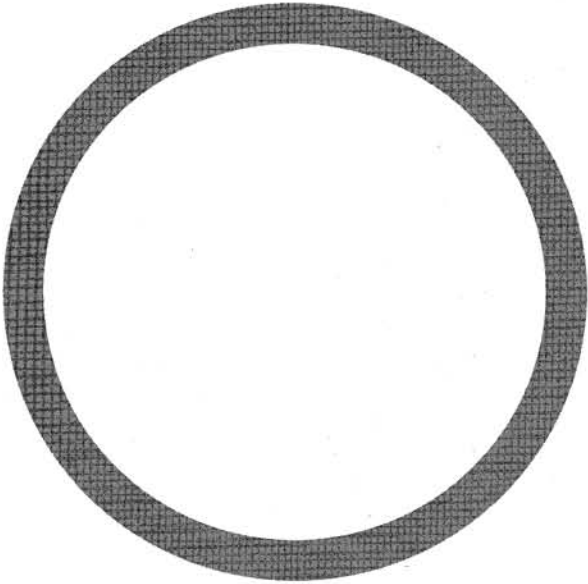

334

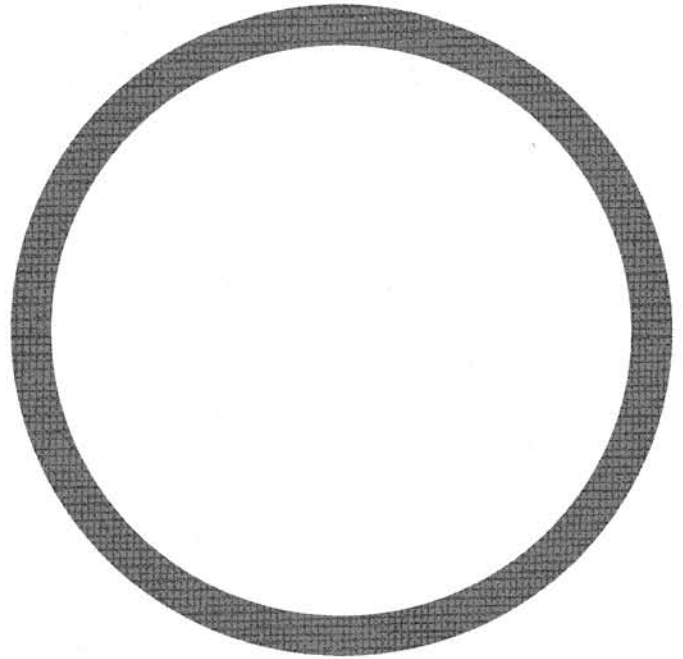

337

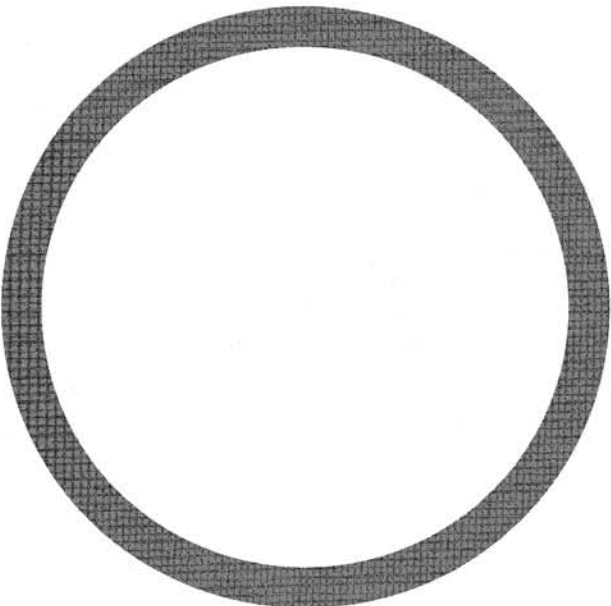

335

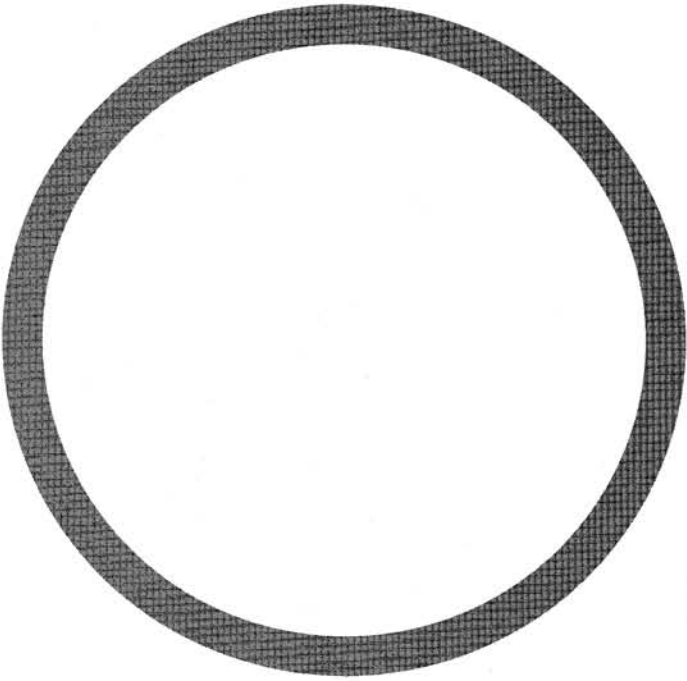

338

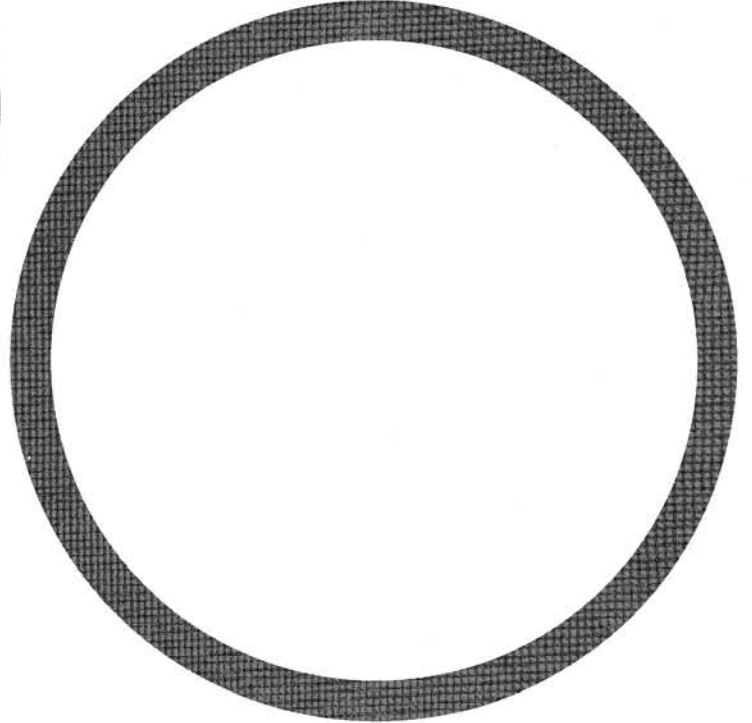

340

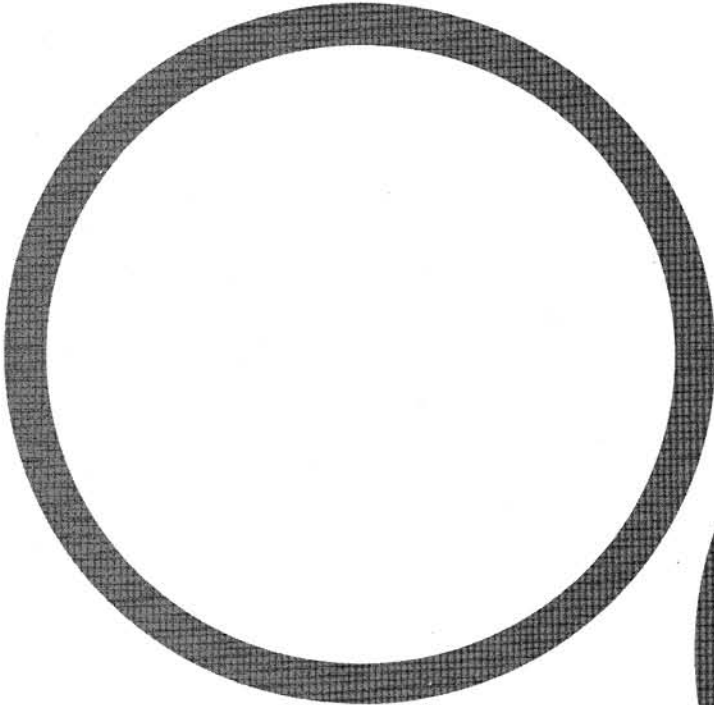

339

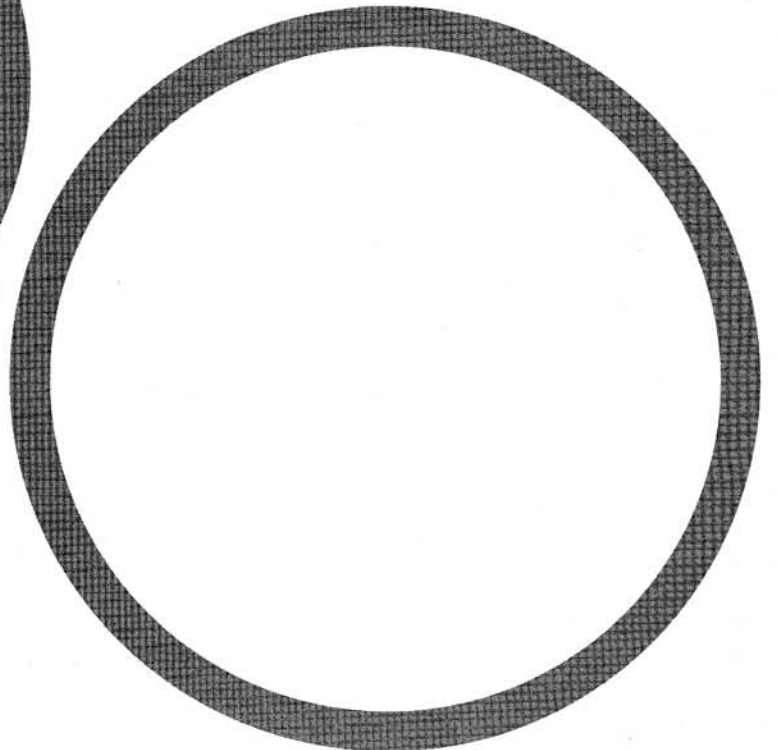

341



300 SERIES

342

352

362

300 SERIES IS SPACED IN TEN NUMBER INCREMENTS

300 SERIES – .210 cross section

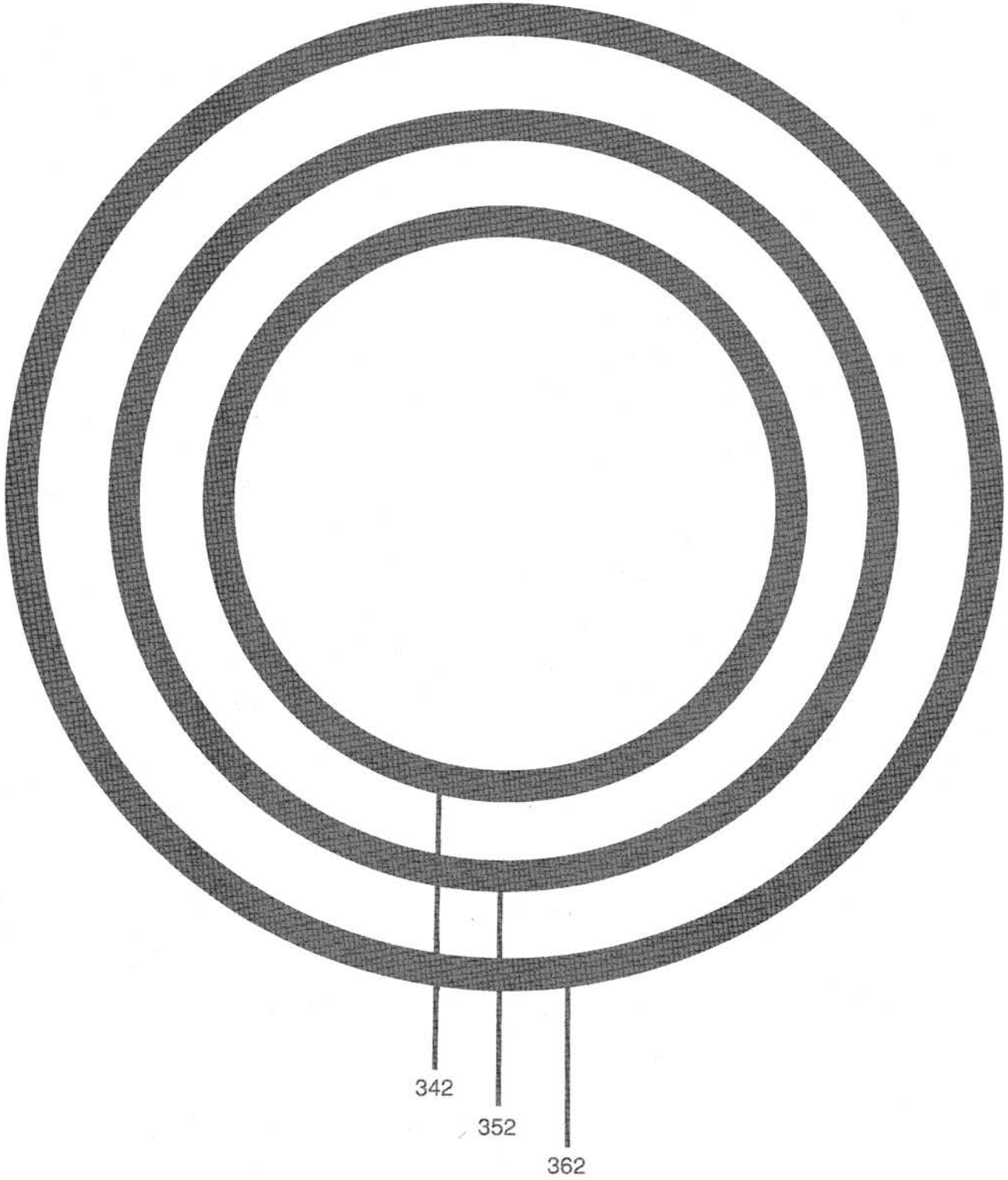

**300 SERIES    343    353    363**

300 SERIES IS SPACED IN TEN NUMBER INCREMENTS

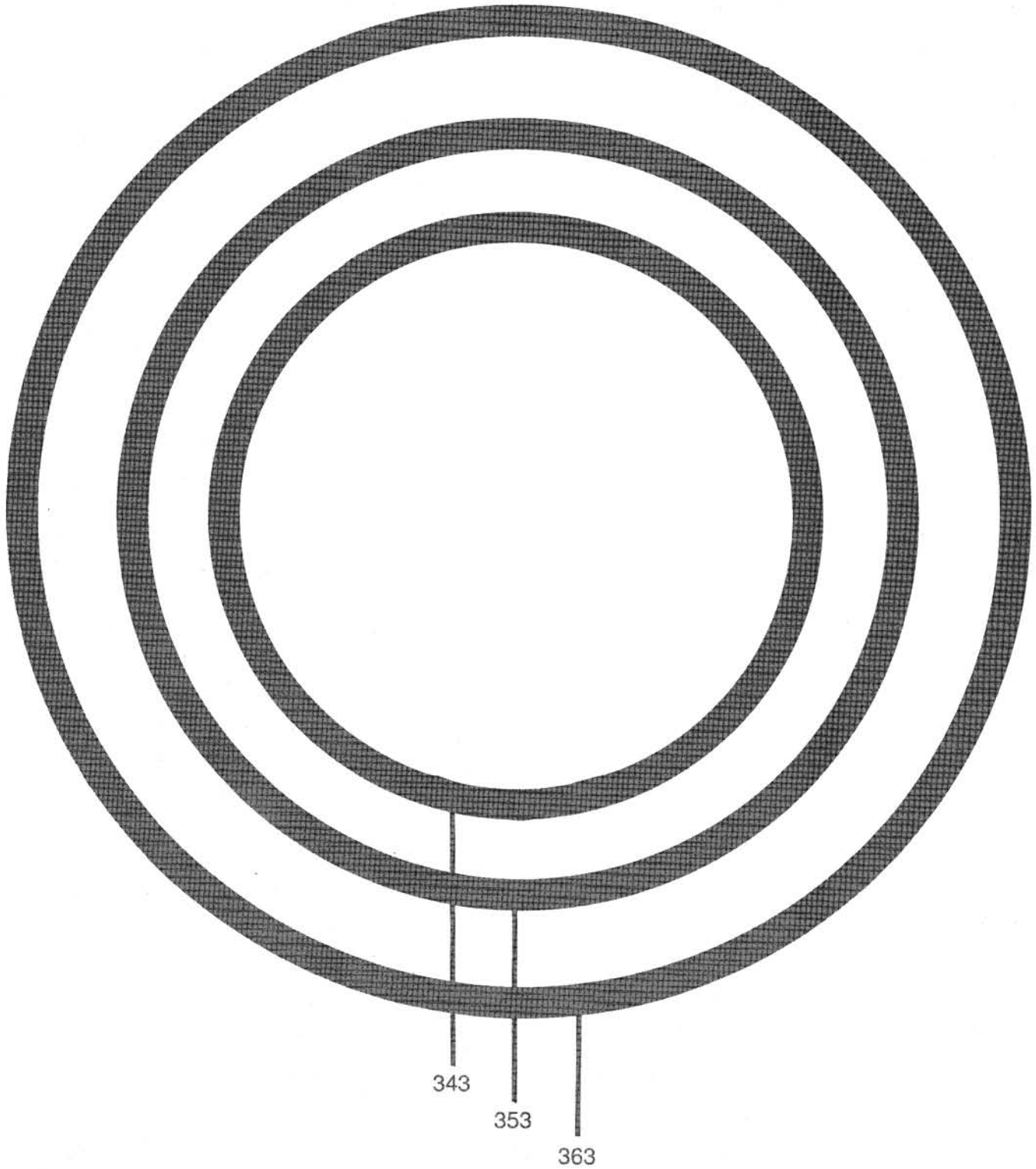

300 SERIES – .210 cross section

300 SERIES 344 354 364

300 SERIES IS SPACED IN TEN NUMBER INCREMENTS

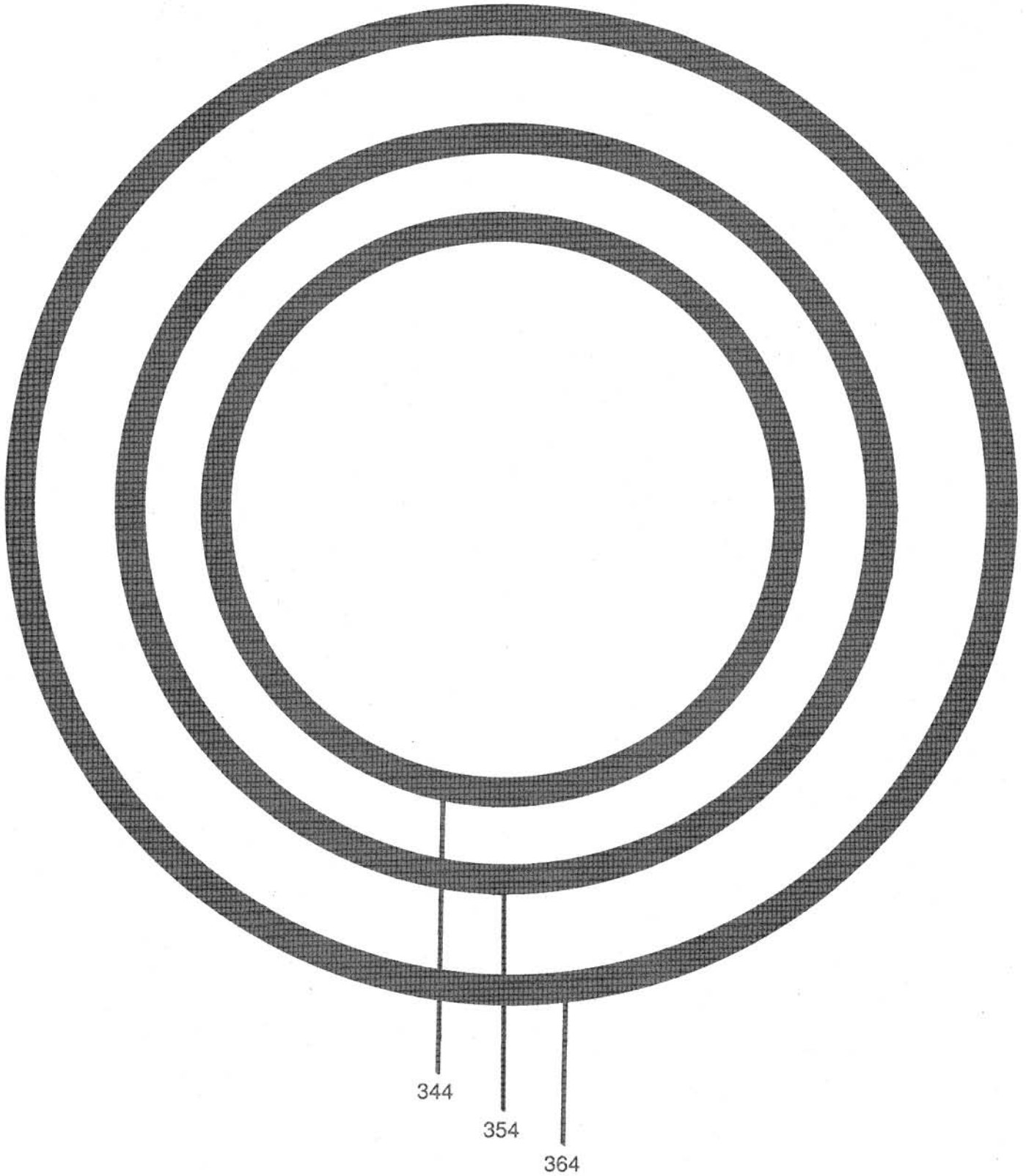

300 SERIES – .210 cross section

300 SERIES 345 355 365

300 SERIES IS SPACED IN TEN NUMBER INCREMENTS

300 SERIES – .210 cross section

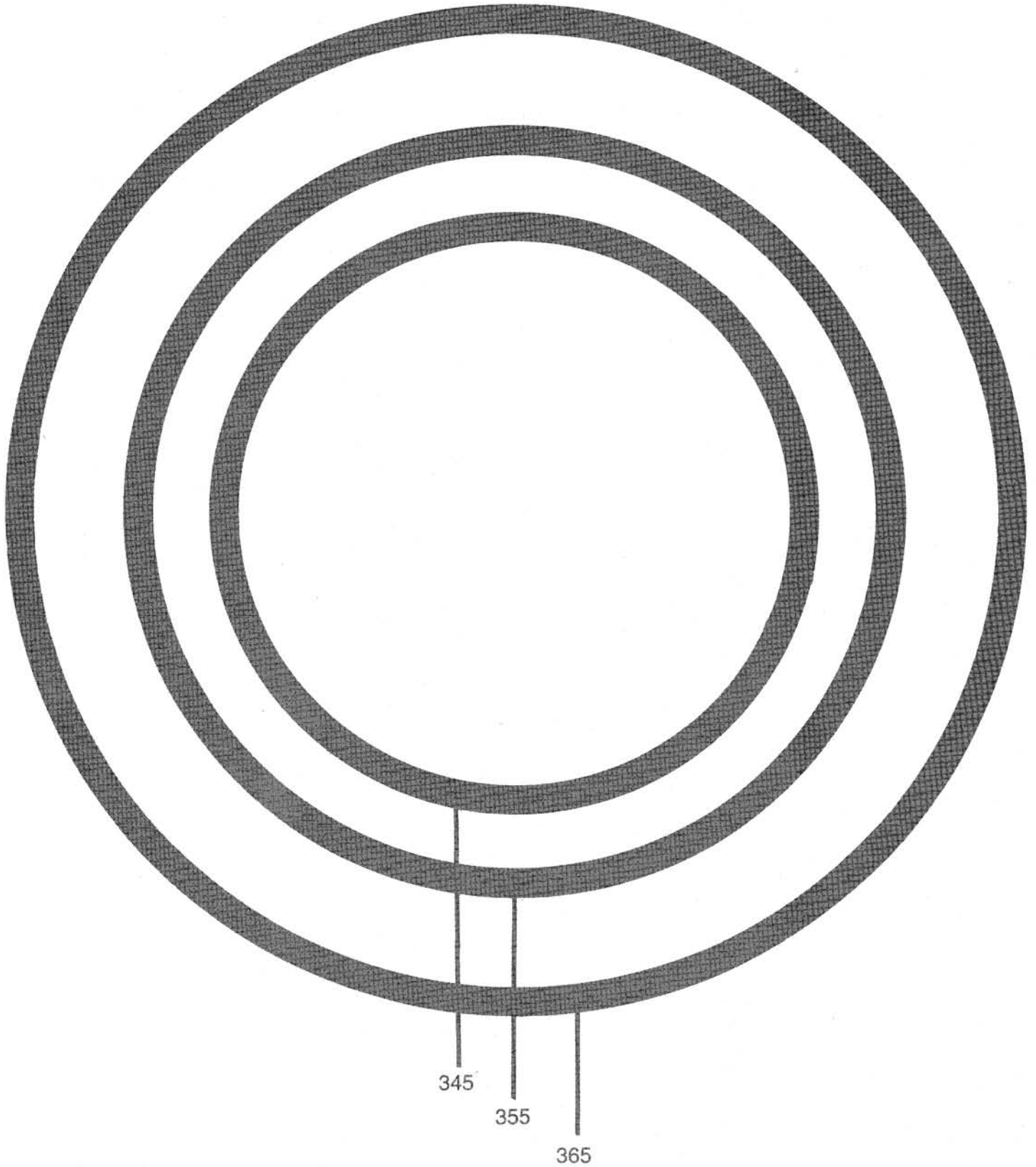

300 SERIES

346

356

300 SERIES IS SPACED IN TEN NUMBER INCREMENTS

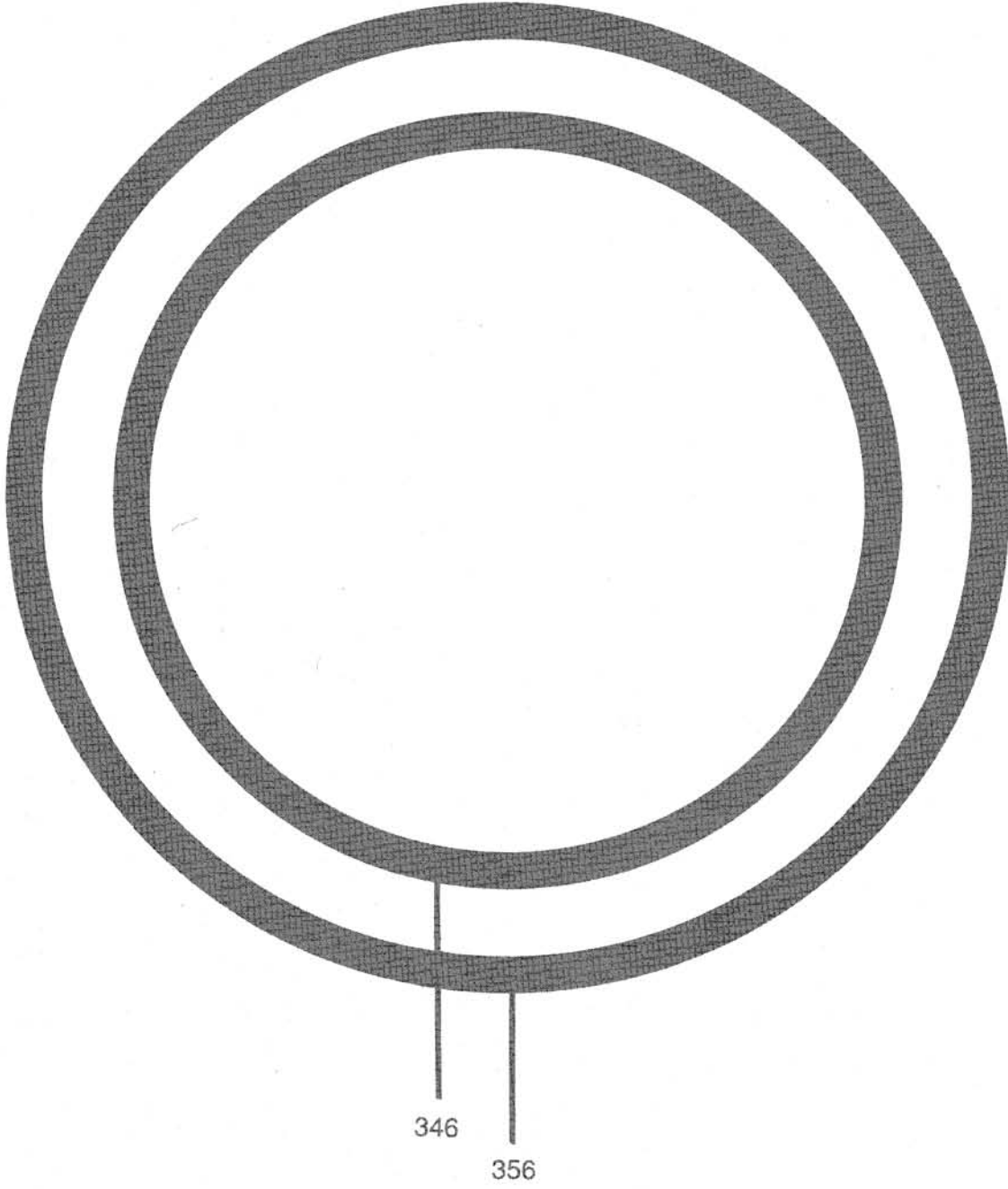

300 SERIES – .210 cross section

300 SERIES 347 357

300 SERIES IS SPACED IN TEN NUMBER INCREMENTS

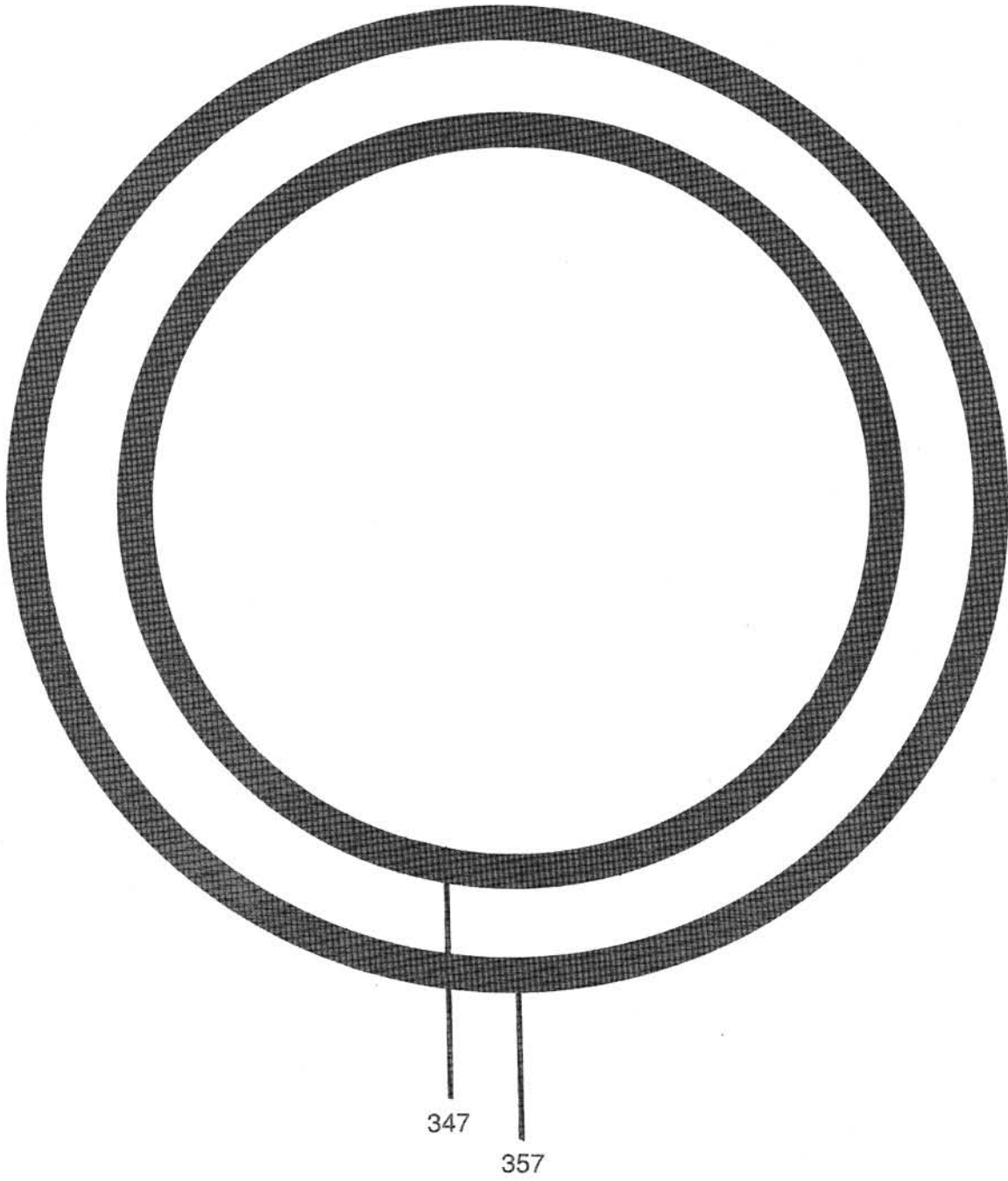

300 SERIES – .210 cross section

300 SERIES

348

358

300 SERIES IS SPACED IN TEN NUMBER INCREMENTS

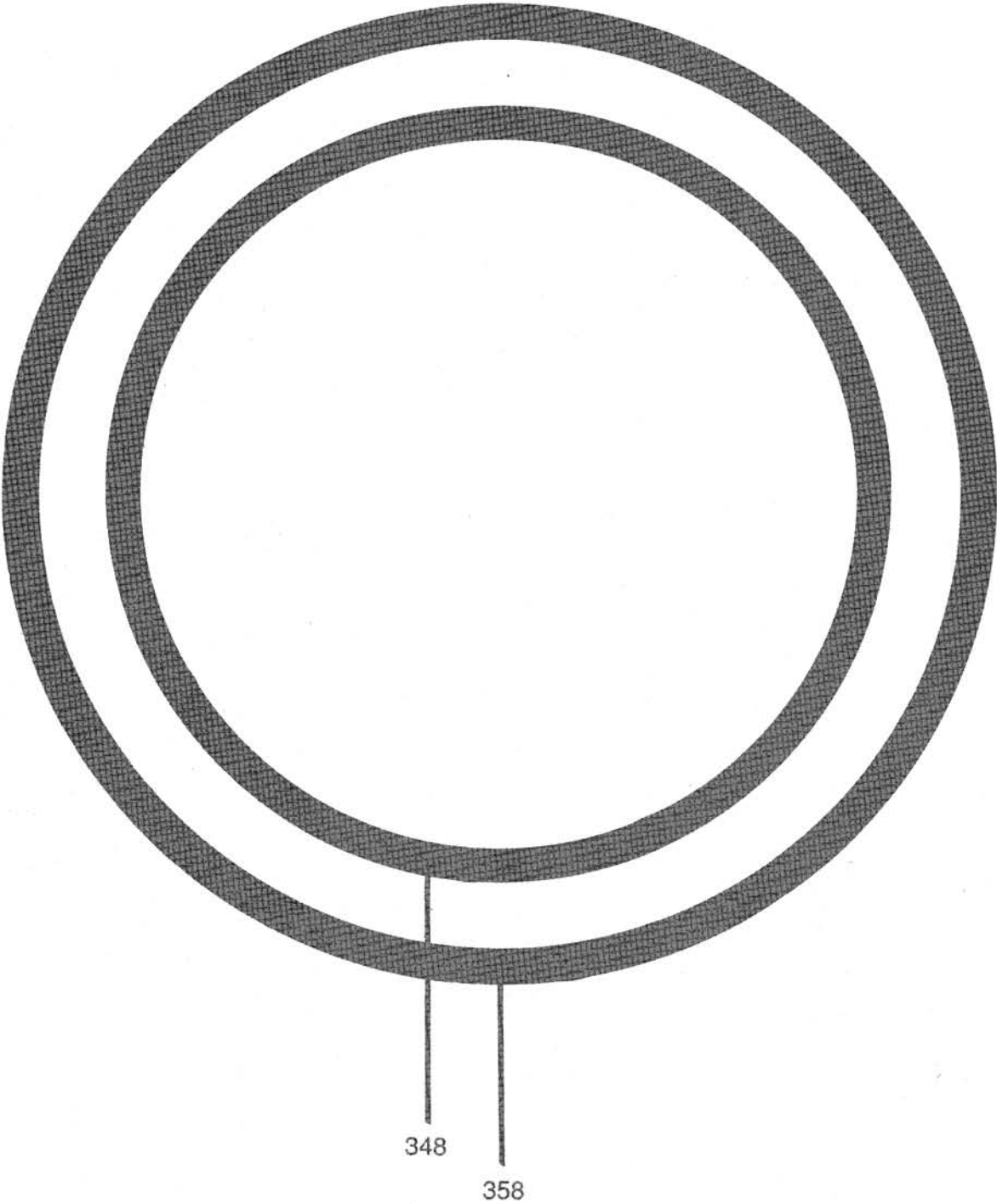

300 SERIES – .210 cross section

**300 SERIES**

**349**

**359**

300 SERIES IS SPACED IN TEN NUMBER INCREMENTS

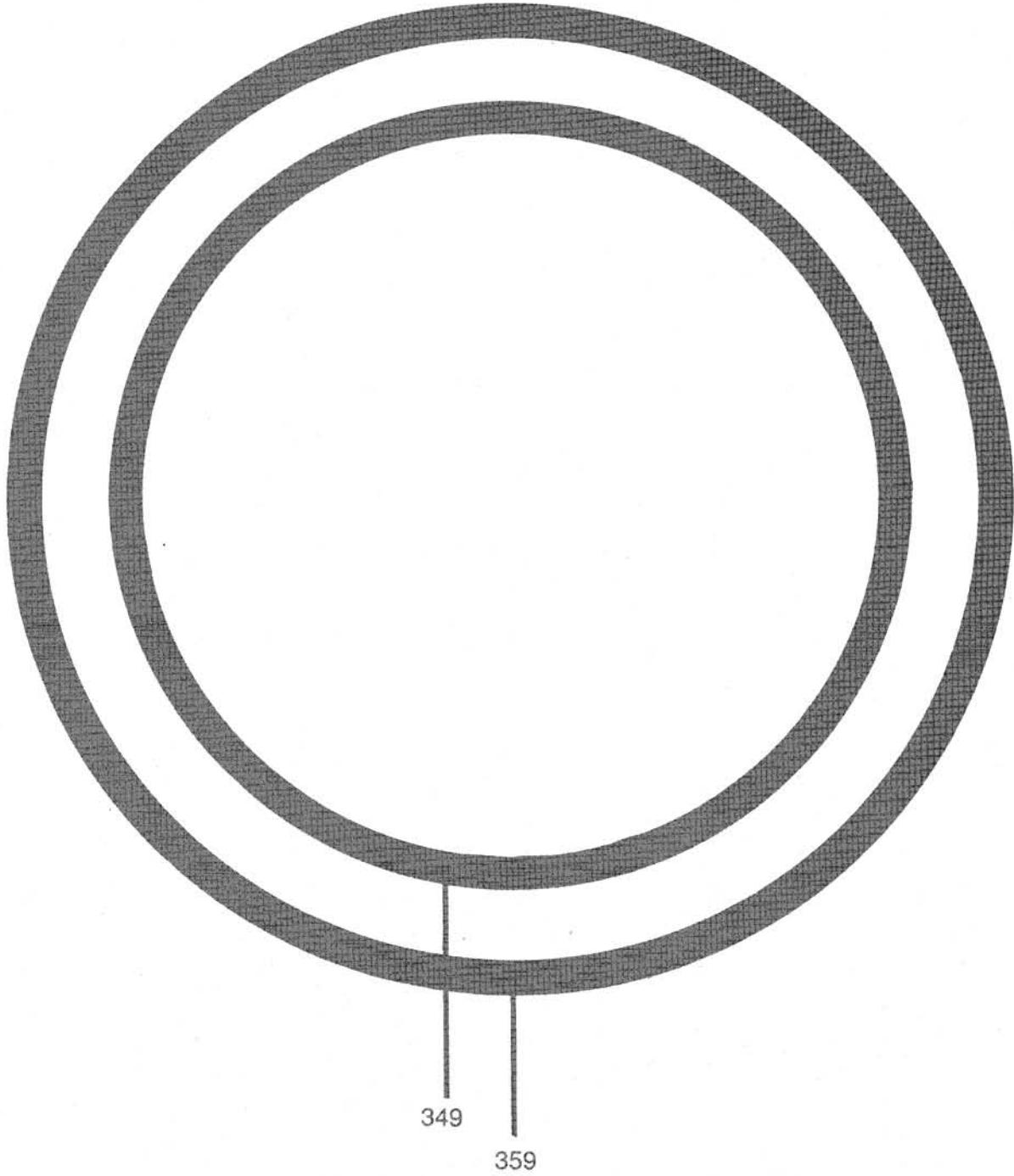

300 SERIES – .210 cross section



300 SERIES 350 360

300 SERIES IS SPACED IN TEN NUMBER INCREMENTS

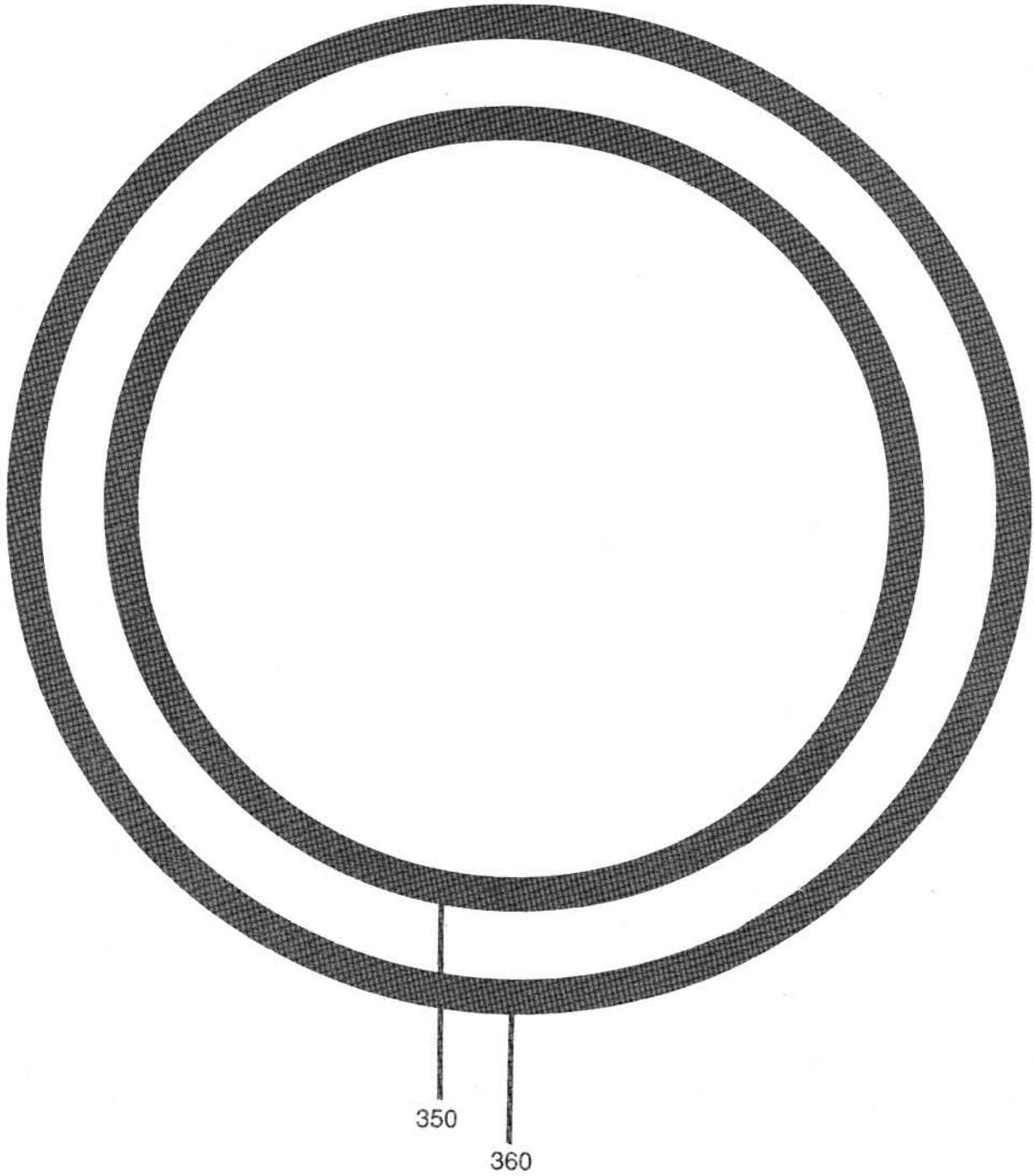

300 SERIES – .210 cross section

**300 SERIES    351    361**

300 SERIES IS SPACED IN TEN NUMBER INCREMENTS

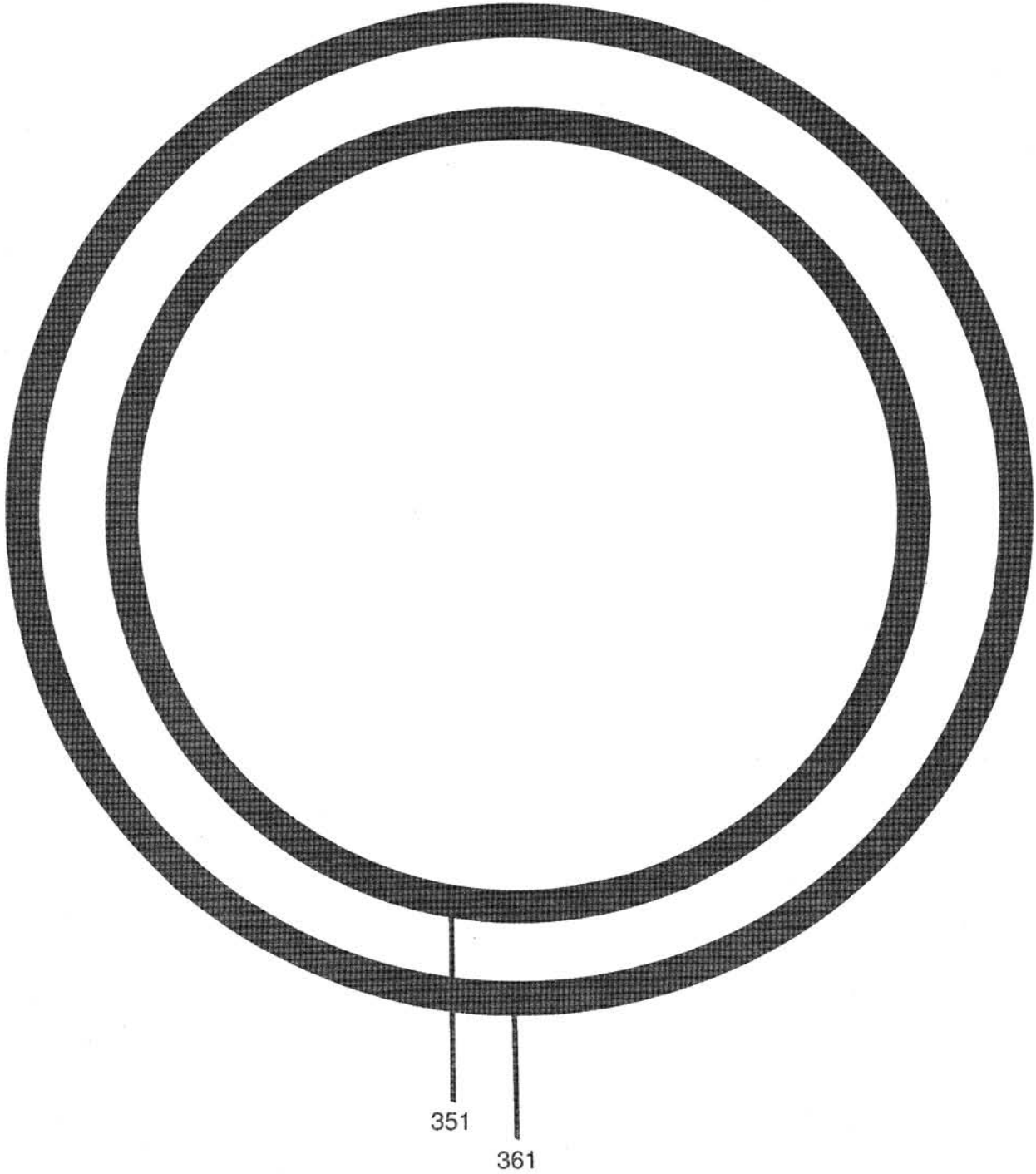

300 SERIES – .210 cross section



Some parts shown are proprietary parts and are not available for resale.

**W**hen it comes to custom molded parts, you'll find that personal attention to your specific needs is our first priority. What's more, we have significantly expanded our custom molding capabilities with the addition of experienced professionals at the tooling and design phases of the process.

Tooling design in a thought stimulating environment is also supplemented by our extensive computer aided design capabilities. Your custom parts production start with the design phase. Our custom molded products are developed using concurrent engineering techniques to assure a time-line from concept to production that has the consensus of both your team and our development staff. This complex task is the result of total coordination of vendors schedules with the allocation of resources to minimize the time required for tooling to be built and samples manufactured.

In short, you can count on us to work with you to design and manufacture products that optimize cost and functionality of your custom needs.



P.O. Box 222, Lebanon, Ohio 45036 • Telephone 513-932-7379 • FAX 513-932-4493  
[www.newmangasket.com](http://www.newmangasket.com)